

GRAVITY PROBE B PROCEDURE FOR SCIENCE MISSION DEWAR

ABRIEVIATED SCIENCE MISSION DEWAR FUNCTIONAL

To be performed at Vandenberg Air Force Base building 1610/EEB/MST

This document contains non-hazardous operations

P1037

November 12, 2002

Written by:

_____ Date _____
Ned Calder
Cryogenic Test Engineer

Approvals:

_____ Date _____
Dorrene Ross
Quality Assurance

_____ Date _____
Harv Moskowitz
LMMS Safety

_____ Date _____
Rob Brumley
Program Technical Manager

_____ Date _____
Mike Taber
Test Director

_____ Date _____
NASA/KSC Safety

REVISION RECORD

REVISION	ECO	PAGES	DATE

Table of Contents

A. SCOPE.....	2
B. SAFETY	2
B.1. Potential Hazards	2
B.2. Mitigation of Hazards	2
B.3. Mishap Notification	3
C. QUALITY ASSURANCE	3
C.1. QA Notification.....	3
C.2. Red-line Authority	3
C.3. Discrepancies	3
D. TEST PERSONNEL	4
D.1. Personnel Responsibilities.....	4
D.2. Personnel Qualifications	4
D.3. Required Personnel	4
E. REQUIREMENTS.....	4
E.1. Electrostatic Discharge Requirements	4
E.2. Lifting Operation Requirements	4
E.3. Hardware/Software Requirements.....	5
E.4. Instrument Pretest Requirements	5
E.5. Configuration Requirements	7
E.6. Optional Non-flight Configurations.....	7
F. REFERENCE DOCUMENTS.....	7
F.1. Drawings.....	7
F.2. Supporting documentation.....	7
F.3. Additional Procedures.....	8
G. OPERATIONS.....	1
G.1. Pre-Operations Verifications	1
G.2. Verify SMD Ready for Test	1
G.3. Prepare DAS to Collect Data	1
G.4. Verify SMD Performance	1
G.5. Establish Final Configuration	2
H. PROCEDURE COMPLETION	2
I. APPENDIX 1 PRE OPERATIONS CHECKLIST	5
J. APPENDIX 2 POST OPERATIONS CHECKLIST	7
K. APPENDIX 3- CONTINGENCY/EMERGENCY RESPONSES	8

List of Abbreviations and Acronyms

AG-x	Gauge x of Gas Module auxiliary section	MT	Main Tank
AMI	American Magnetics Inc.	MTVC	Main Tank Vent Cap
AP-1	Vane Pump in Gas module	MTVC-G	Main Tank Vent Cap pressure gauge
APR-x	Pressure regulator x of Gas Module	MTVC-RV	Main Tank Vent Cap relief valve
AV-x	Valve x of Gas Module auxiliary section	MTVC-V	Main Tank Vent Cap valve
CG-x	Gauge x of portable helium pressurization source	NBP	Normal boiling point
CPR-x	Pressure regulator x of portable helium pressurization source	ONR	Office of Naval Research
CV-x	Valve x of portable helium pressurization source	PFCG	Fill Cap assembly pressure Gauge
CN [xx]	Data acquisition channel number	PFM	Pump equipment Flow Meter
DAS	Data Acquisition System	PG-x	Gauge x of Pump equipment
EFM-x	Exhaust gas Flow Meters	PM	Pump Module
EG-x	Gauge x of Gas Module exhaust section	psi	pounds per square inch
EH-x	Vent line heat exchanger in GM	psig	pounds per square inch gauge
EM	Electrical Module	PTD	Payload Test Director
ERV-x	Relief valve of Gas Module exhaust section	PV-x	Valve x of the Pump equipment
EV-x	Valve number x of Gas Module exhaust section	QA	Quality Assurance
FCV	Fill Cap Valve	RAV-x	Remote Actuated Valve-x
FIST	Full Integrated System Test	RGA	Residual Gas Analyzer
GHe	Gaseous Helium	RGA-LV	RGA leak valve (needle valve)
GM	Gas Module	RGA-SOV	RGA shut off valve
GP-B	Gravity Probe-B	SMD	Science Mission Dewar
GSE	Ground Support Equipment	STV	SMD Thruster vent Valve
GT	Guard Tank	SU	Stanford University
GTVC	Guard Tank Vent Cap	SV-x	SMD Valve number x
GTVC-G	Guard Tank Vent Cap pressure gauge	TG-x	Gauge x of Utility Turbo System
GTVC-RV	Guard Tank Vent Cap relief valve	TV-x	Valve x of Utility Turbo System
GTV-G	Guard Tank vent pressure gauge	UTS	Utility Turbo System
GTV-RV	Guard Tank vent relief valve	Vac	Vacuum
GTV-V	Guard Tank vent valve	VCP-x	Vent cap pressure gauge
GTV-Va	Guard Tank Vent line valve for independent pressure regulation	VCRV-x	Vent cap relief valve
HEX-x	SMD heat exchanger x	VCV-x	Vent cap valve
KFxx	Quick connect o-ring vacuum flange (xx mm diameter)	VDC	Volts Direct Current
LHe	Liquid Helium	VF-x	Liquid helium Fill line valve
LHSD	Liquid Helium Supply Dewar	VG-x	Gauge x of Vacuum Module
LHV-x	Liquid Helium Supply Dewar valves	VM	Vacuum Module
LLS	Liquid level sensor	VV-x	Valve x of Vacuum Module
LM	Lockheed Martin Co.	VW-x	Valve x of Dewar Adapter

LIST OF SPECIFIC HEADING DEFINITIONS

Each type of alert message will precede the procedural step to which it applies

1. NOTE: Used to indicate an operating procedure of such importance that it must be emphasized
2. CAUTION: Used to identify hazards to equipment
3. WARNING: Used to identify hazards to personnel

A. SCOPE

This procedure describes the steps to perform an abbreviated functional (test of thermal performance) test of the GP-B Science Mission Dewar. This procedure is to be run after any major transportation or period in which the health and status of the SMD have not been continuously monitored. This procedure provides the option of being performed in building 1610, or the EEB and MST.

B. SAFETY**B.1. Potential Hazards**

Personal injury and hardware damage can result during normal positioning, assembly and disassembly of hardware.

Liquid helium used in the SMD represents a hazardous material for the personnel involved in the operations. Cryogenic burns can be caused by contact with the cold liquid or gas, high pressures can result if boiling liquid or cold gas is confined without a vent path, and asphyxiation can result if the vent gas is allowed to accumulate.

The SMD Safety Compliance Assessment, document GPB-100153C and the Missile System Prelaunch Safety Package, LM/P479945 discuss the safety design, operating requirements and the hazard analysis of the SMD.

B.2. Mitigation of Hazards**B.2.1. Lifting hazards**

There are no lifting operations in this procedure

B.2.2. Cryogenic Hazards

In VAFB building 1610 and the MST, the GP-B cryogenic team provides an oxygen deficiency monitor that alarms when the oxygen level is reduced to 19.5%. Additional temperature and pressure alarms, provided by the DAS, warn of potential over-pressure conditions. Emergency vent lines are installed over the four burst disks to direct any flow to an outside area.

Only authorized and trained personnel are allowed in VAFB facilities without escort. All personnel working on platforms at a height 30 inches or more off the floor are required to have an approved air tank (emergency breathing apparatus) within easy reach. Note that tank need not be kept available when working from ladder. In the unlikely event of a large LHe spill all employees have been instructed to evacuate the building and contact NASA Safety.

The following additional requirements apply to all personnel involved directly in cryogenic operations. Gloves that are impervious to liquid helium and liquid nitrogen are to be worn whenever the possibility of splashing or impingement of high-velocity cryogenics exists or when handling equipment that has been cooled to cryogenic temperatures. Protective clothing, non-absorbent shoes, goggles/glasses and full-face

shields are to be worn whenever the possibility of splashing cryogenics exists.

B.2.3. Other Hazards

When appropriate, tools or other items used with the potential to damage the space vehicle shall be tethered.

B.3. **Mishap Notification**

B.3.1. Injury

In case of any injury obtain medical treatment as follows
VAFB **Call 911**

B.3.2. Hardware Mishap

In case of an accident, incident, or mishap, notification is to proceed per the procedures outlined in Lockheed Martin Engineering Memorandum EM SYS229 and Stanford University GP-B P0879. Additionally, VAFB NASA Safety and 30th Space Wing Safety will be notified as required.

B.3.3. Contingency Response

Responses to contingencies/emergency (e.g., power failure) are listed in Appendix 3.

C. **QUALITY ASSURANCE**

C.1. **QA Notification**

The NASA program and the NASA safety representative and SU QA shall be notified 24 hours prior to the start of this procedure. Upon completion of this procedure, the QE Manager will certify his/her concurrence that the effort was performed and accomplished in accordance with the prescribed instructions by signing and dating in the designated place(s) in this document.

C.2. **Red-line Authority**

Authority to red-line (make minor changes during execution) this procedure is given solely to the TD or his designate and shall be approved by the QA Representative. Additionally, approval by the Payload Technical Manager shall be required, if in the judgement of the TD or QA Representative, experiment functionality may be affected.

C.3. **Discrepancies**

A Quality Assurance Representative designated by D. Ross shall review any discrepancy noted during this procedure, and approve its disposition. Discrepancies will be recorded in a D-log or a DR per Quality Plan P0108. Any time a procedure calls for verification of a specific configuration and that configuration is not the current configuration, it represents a discrepancy of one of three types. These types are to be dealt with as described below.

1. If the discrepancy has minimal effect on procedure functionality (such as the state of a valve that is irrelevant to performance of the procedure) it shall be documented in the procedure, together with the resolution. Redlines to procedures are included in this category.
2. If the discrepancy is minor and affects procedure functionality but not flight hardware fit or function, it shall be recorded in the D-log. Resolution shall be in consultation with the PTD and approved by the QA representative.
3. All critical and major discrepancies, those that effect flight hardware fit or functions, shall be documented in a D-log and also in a Discrepancy Report, per P0108.

D. TEST PERSONNEL

D.1. Personnel Responsibilities

The performance of this procedure requires a minimum complement of personnel as determined by the Test Director. The person performing the operations (Test Director or Test Engineer) is to sign the "Completed by" sign-off. Any other qualified person or QA person who can attest to the successful performance of this procedure may sign the "Witnessed by" sign-off. The Test Director will perform Pre-Test and Post-Test Briefings in accordance with P0875 "GP-B Maintenance and Testing at all Facilities." Checklists will be used as directed by P0875

D.2. Personnel Qualifications

The Test Director must have a detailed understanding of all procedures and facility operations and experience in all of the SMD operations. Test Engineers must have SMD Cryogenic operations experience and an understanding of the operations and procedures used for the cryogenic servicing/maintenance of the Dewar.

D.3. Required Personnel

Required Personnel

The following personnel are essential to the accomplishment of this procedure:

FUNCTIONAL TITLE	NUMBER	AFFILIATION
Test Director/Test Engineer	1	Stanford
GP-B Quality Assurance	1	Stanford

E. REQUIREMENTS

E.1. Electrostatic Discharge Requirements

None

E.2. Lifting Operation Requirements

There are no lifting operations in this procedure

E.3. Hardware/Software Requirements

E.3.1. Commercial Test Equipment

None

E.3.2. Ground Support Equipment

The Ground Support Equipment includes the Gas Module, the Electrical Module. The Gas Module provides the capability to configure vent paths, read pressures and flow rates, and pump and backfill vent lines. The Pump Module provides greater pumping capacity than the Gas Module, together with additional flow metering capabilities. The vent output of the Gas Module flows through the Pump Module. The Electrical Module contains the instruments listed in Table 1, and provides remote control of valves in the Gas Module, Pump Module, and SMD.

E.3.3. Computers and Software:

The Data Acquisition System (DAS) is required for this procedure. The DAS reads and displays pressures, temperatures, and flow rates and monitors critical parameters. No additional computers or software are required.

E.3.4. Additional Test Equipment

1. none

E.3.5. Additional Hardware

1. none

E.3.6. Tools

<i>Description</i>
N/A

E.3.7. Expendables

<i>Description</i>	<i>Quantity</i>	<i>Mfr./Part No.</i>
N/A	NA	N/A

E.4. Instrument Pretest Requirements

The GSE instruments required to perform this procedure are listed in Table 1, together with their serial numbers, where available. Instruments that are required to have current calibrations are indicated in the Cal-Required column. Instruments that do not require calibration are those not used to verify performance requirements and are not connected to flight instrumentation. The status column is to be filled in with the due date of the instrument calibration sticker and verified to be in calibration by QE or QE designee.

Table 1. Required Instrumentation and Calibration Status

No.	Location	Description	Name	Serial No.	Cal Required	Status Cal due date
1	DAS	Power Supply, H-P 6627A	-	3452A01975	Yes	-
2	DAS	Power Supply, H-P 6627A	-	3452A01956	Yes	-
3	DAS	Data Acquisition/Control Unit H-P 3497A	-	2936A245539	No	-
4	DAS	Digital Multimeter H-P 3458A	-	2823A15047	Yes	-
5	EM	Vacuum Gauge Controller Granville-Phillips Model 316	EG-1a, -1b	2827	No	-
6	EM	Vacuum Gauge Controller Granville-Phillips Model 316	AG-2a, -2b	2826	No	-
7	EM	Vacuum Gauge Controller Granville-Phillips Model 316	EG-3	2828	No	-
8	EM	MKS PDR-C-2C	EG-2, FCG	92022108A	No	-
9	EM	Flow meter – Matheson 8170	EFM-1	96186	No	-
10	EM	Flow meter totalizer Matheson 8124	EFM-1	96174	No	-
11	EM	Liquid Helium Level Controller American Magnetics, Inc. 136	LLS Main Tank	96-409-11	No	-
12	EM	Liquid Helium Level Controller American Magnetics, Inc. 136	LLS Guard Tank	96-409-10	No	-
13	EM	Liquid Helium Level Controller American Magnetics, Inc. 136	LLS Well	96-409-9	No	-
14	EM	Liquid Helium Level Controller American Magnetics, Inc. 136	LLS Axial Lock	96-409-12	No	-
15	EM	Pressure Controller – MKS 152F-92	EV-7a, -7b	96203410A	No	-
16	EM	Power Supply HP 6038A	H08D Tank Heater	96023407A	Yes	-
17	EM	Power Supply HP 6038A	H09D Tank Heater	3511A-13332	Yes	-
18	EM	Power Supply HP 6038A	RAV Power Supply	3329A-12486	Yes	-
19	EM	Vac Ion Pump power supply Varian 929-0910, Minivac	SIP	5004N	No	-
20	EM	Flow meter totalizer Veeder-Root	PFM-1	576013-716	No	-
21	GM	Pressure Gauge, Heise	AG-1	CC-122077	No	-
22	GM	Pressure Gauge, Marshall Town	AG-3	N/A	No	-
23	GM	Main Tank Heat Exchanger: a) Thermocouple, b) Current meter, c) Temperature set point controller	-	C-19950	No	-
24	GM	Guard Tank Heat Exchanger: a) Thermocouple, b) Current meter, c) Temperature set point controller	-	C-09920	No	-
25	VM	Vacuum Gauge readout, Granville-Phillips 316	VG-3 VG-4	2878	No	-
26	VM	Vacuum Gauge readout, Granville-Phillips 360	VG-1, VG-2 VG-5	96021521	No	-

E.5. Configuration Requirements**E.5.1. Main Tank**

Liquid in the Main Tank must be at its normal boiling point (NBP) or Subatmospheric

E.5.2. Guard Tank

The Guard Tank may contain liquid or be depleted.

E.5.3. Well

The Well must be evacuated.

E.5.4. SMD Vacuum Shell

The Vacuum Shell pressure must be less than 5×10^{-5} torr. Document No. P1015, *Connect Vacuum Module to SMD*, contains the procedure for connecting to and pumping on the SMD vacuum shell.

E.5.5. Alarm System

1. The DAS alarm system must be enabled and contain the following alarm set-points:
 - a. Top of lead bag temperature set (CN 175 and CN178) at $T \leq 6.0$ K.
 - b. Relative Guard Tank Pressure (CN 46) set at $P \geq 10$ torr.

E.5.6. GSE and Non-flight Hardware

1. N/A

E.6. Optional Non-flight Configurations

The following modifications or non-flight arrangement of the basic SMD configuration may also be in place. They are incidental to the performance of this procedure and not required.

1. The SMV {SMD?} may be installed in its transportation and test fixture.
2. The Vacuum shell pump out port at SV-14 may be connected to the Vacuum Module (P/N 5833816) via a 2-in valve and pumping line, with the valve in either the closed position or in the open position. The Vacuum Module pump may be; off, actively pumping the pumping line up to a closed SV-6, or actively pumping the vacuum shell.

F. REFERENCE DOCUMENTS**F.1. Drawings**

<i>Drawing No.</i>	<i>Title</i>
LMMS-5833394	Instrumentation Installation

F.2. Supporting documentation

<i>Document No.</i>	<i>Title</i>
LMMC-5835031	GP-B Magnetic Control Plan
GPB-100153C	SMD Safety Compliance Assessment
LM/P479945	Missile System Prelaunch Safety Handbook

SU/GP-B P0141	FIST Emergency Procedures
LMSC-P088357	Science Mission Dewar Critical Design Review
SU/GP-B P0108	Quality Plan
LMMS GPB-100333	Science Mission Dewar Failure Effects and Causes Analysis
SU/GP-B P059	GP-B Contamination Control Plan
EM SYS229	Accident/Mishap/Incident Notification Process
EWR 127-1	Eastern and Western Range Safety Requirements
KHB 1710.2 rev E	Kennedy Space Center Safety Practices Handbook

F.3. **Additional Procedures**

<i>Document No.</i>	<i>Title</i>
SU/GP-B P0879	Accident/Incident/Mishap Notification Process
SU/GP-B P1015	Connect Vacuum Module to SMD
SU/GP-B P0875	GP-B Maintenance and Testing at all Facilities

Operation Number: _____

Date Initiated: _____

Time Initiated: _____

G. OPERATIONS**G.1. Pre-Operations Verifications**

- o Verify SU QA notified.
Record: Individual notified _____,
Date/time ____/____.
- o Verify NASA program representative notified.
Record: Individual notified _____,
- o Record calibration due dates in Table 1 (Sections. E.3.4, E.4)
- o Persons actually performing this procedure should list their names in Sec D.3.
- o Verify completion of the pre-operations checklist (Appendix 1).
- o Verify proper operation of GP-B Cryogenic Team oxygen monitor
- o Verify availability and functioning of an emergency shower

Section Complete QA Witness: _____

G.2. Verify SMD Ready for Test

- G.2.1. Verify P0773 or P1020, "Certification of the Electrical Module, Gas Module and Data Acquisition System, " has been completed since the last transportation of the Payload GSE.
- G.2.2. Verify P0791 or P1013, "Connect Electrical GSE to Payload," has been performed since the last transportation of the Payload.

G.3. Prepare DAS to Collect Data

- G.3.1. Verify the data scan is producing appropriate output for all channels.
- G.3.2. Ensure plotter set-up to plot all temperature output of the SMD over a time of ~6 hours
- G.3.3. Adjust DAS data cycle interval to between 5-10 minutes

G.4. Verify SMD Performance

- G.4.1. Verify more than two hours of data have been recorded and plotted
- G.4.2. Verify all channels are plotting within limits of plotter
- G.4.3. Verify no channel has anomalous behavior- annotate any discrepancies below _____

G.4.4. Attach data print out including the page of status data and a copy of the plot results to this procedure

Section Complete QA Witness: _____

G.5. **Establish Final Configuration**

G.5.1. Verify performance of post-operations checklist (Appendix 2)

Section Complete QA Witness: _____

H. **PROCEDURE COMPLETION**

Completed by: _____

Witnessed by: _____

Date: _____

Time: _____

Quality Manager _____ Date _____

Payload Test Director _____ Date _____

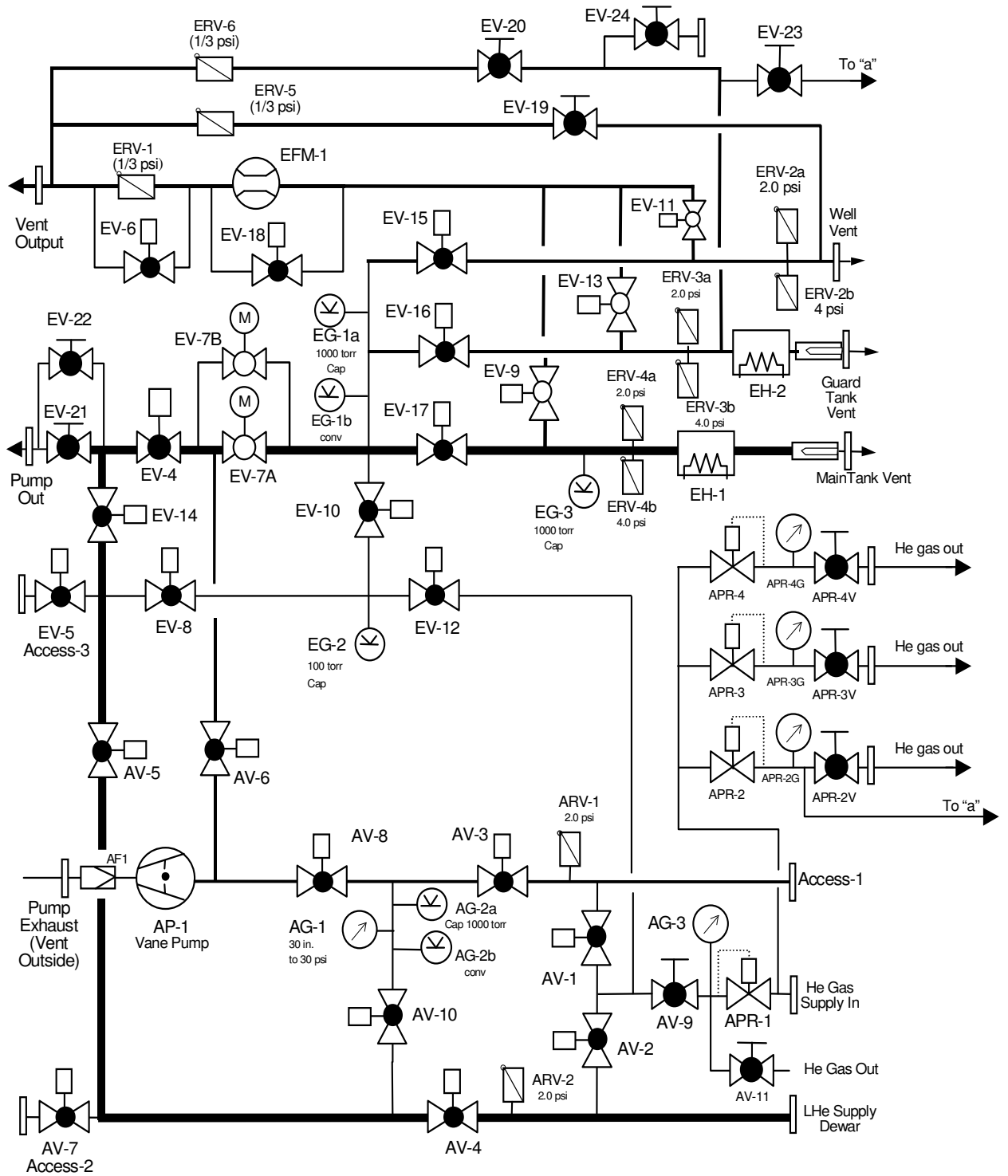

Figure 1. Gas Module

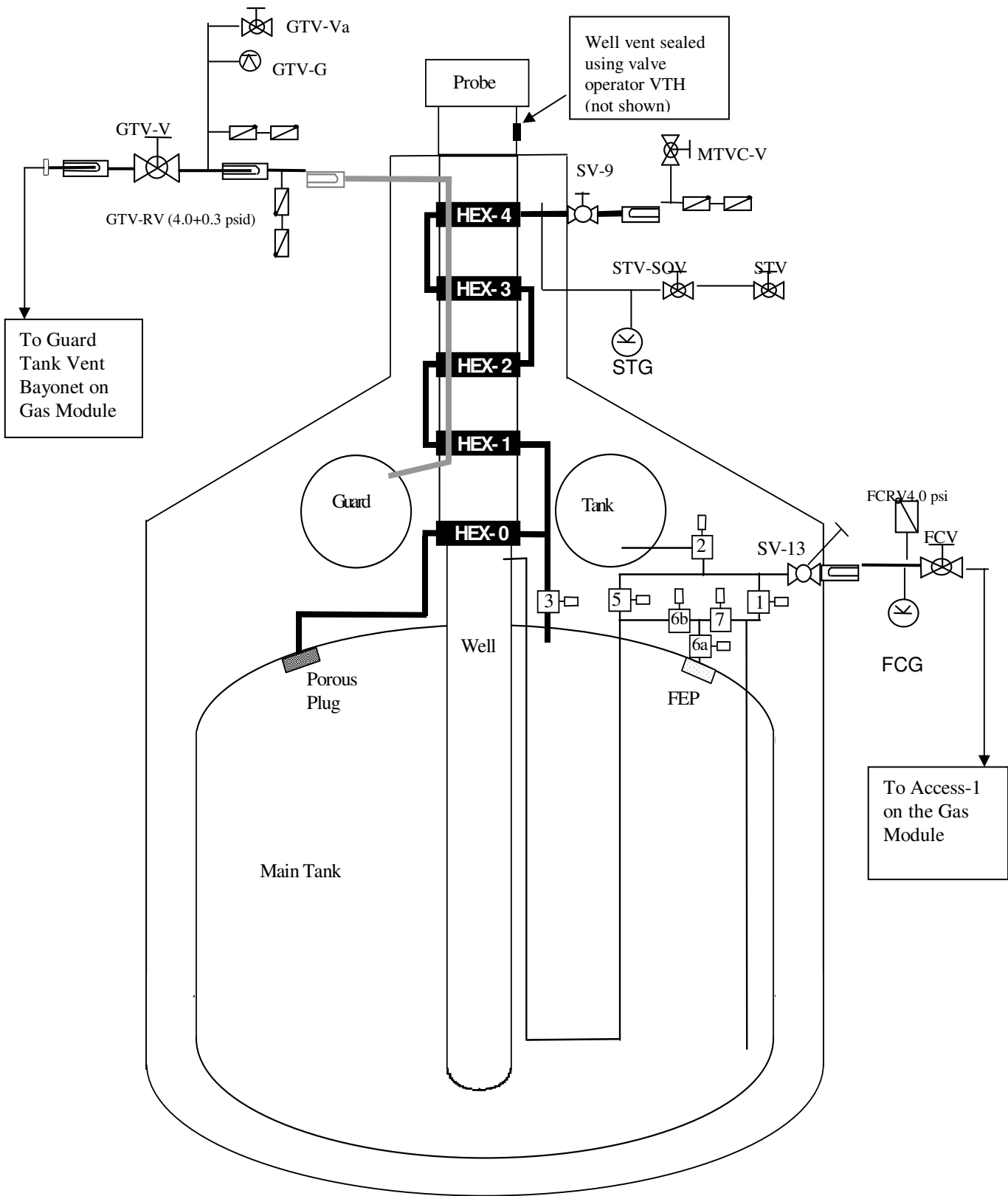

Figure 4 Schematic representation of SMD showing interfaces with Gas module.

I. **APPENDIX 1 PRE OPERATIONS CHECKLIST**

DATE	CHECKLIST ITEM	COMPLETED	REMARKS
	1. Verify the test procedure being used is the latest revision.		
	2. Verify all critical items in the test are identified and discussed with the test team.		
	3. Verify all required materials and tools are available in the test area.		
	4. Verify all hazardous materials involved in the test are identified to the test team.		
	5. Verify all hazardous steps to be performed are identified to the test team.		
	6. Verify each team member is certified for the task being performed and knows their responsibilities.		
	7. Confirm that each test team member clearly understands that he/she has the authority to stop the test if an item in the procedure is not clear.		
	8. Confirm that each test team member clearly understands that he/she must stop the test if there is any anomaly or suspected anomaly.		
	9. Notify management of all discrepancy reports or d-log items identified during procedure performance. In the event an incident or major discrepancy occurs during procedure performance management will be notified immediately.		
	10. Verify/Perform pre-test engineering/safety high bay walk down. Verify noted discrepancies have been corrected.		
	11. Confirm that each test team member understands that there will be a post-test team meeting.		

	Team Lead Signature: _____		
--	-------------------------------	--	--

J. APPENDIX 2 POST OPERATIONS CHECKLIST

DATE	CHECKLIST ITEM	COMPLETED	REMARKS
	1. Verify all steps in the procedure were successfully completed.		
	2. Verify all anomalies discovered during testing are properly documented.		
	3. Ensure management has been notified of all major or minor discrepancies.		
	4. Ensure that all steps that were not required to be performed are properly identified.		
	5. If applicable sign-off test completion.		
	6. Verify all RAV valve operations have been entered in log book		
	7. Verify the as-run copy of procedure has been filed in the appropriate binder		
	Team Lead Signature: _____		

K. **APPENDIX 3– CONTINGENCY/EMERGENCY RESPONSES**

Condition	Circumstance	Response
Power Failure	Anytime	Wait for power restoration and resume procedure
Liquid nitrogen spill	Anytime	Clear area until all spilled liquid has evaporated
Temperature limits (CN 29 or 28) exceeded	Any time	Increase Main Tank venting
Burst disk rupture (MT/GT)	Any time	Evacuate room
Pressure in Main Tank exceeds limit	Anytime	Increase Main Tank venting to relieve pressure in Main Tank
Oxygen Monitor Alarm	Anytime	Evacuate building