

GRAVITY PROBE B PROCEDURE FOR SCIENCE MISSION DEWAR

EXTERNAL GUARD TANK FILL – MAIN TANK SUBATMOSPHERIC

To be performed at Vandenberg Air Force Base building 1610

WARNING: THIS DOCUMENT CONTAINS HAZARDOUS OPERATIONS

P1027A
September 16, 2003
ECO 1449

Written by:

Checked by:

Date _____
Ned Calder
Cryogenic Test

Date _____
Dave Murray
Cryogenic Test

Approvals:

Date _____
Dorrene Ross
Quality Assurance

Date _____
Harv Moscowitz
LM Safety

Date _____
Robert Brumley

Date _____
Mike Taber
Payload Test Director

Date _____
NASA/KSC Safety

REVISION RECORD

| REVISION | ECO | Description | DATE |
|-----------------|------------|--|-------------|
| A | 1449 | <p>Update RAV-2 operations (operated by the spacecraft instead of by GSE)</p> <p>Clarified note explaining reason for switching from AP-1 to Pump Module</p> <p>Changed sequence of steps: sting LHSD before opening RAV-2.</p> <p>Added use of line to vent pre-cool gas to outside</p> <p>Added Figures 2 (Schematic of Pump Module), 3 (Schematic of SMD and GSE Plumbing), and 4 (Schematic of LHSD and Transfer Line Plumbing)</p> <p>Added contingency responses to failure of RAV-2 to operate in Appendix 3</p> <p>Various minor corrections</p> | |

Table of Contents

| | | |
|----|---|----|
| A. | SCOPE..... | 2 |
| B. | SAFETY | 2 |
| | B.1. Potential Hazards..... | 2 |
| | B.2. Mitigation of Hazards | 2 |
| | B.3. Mishap Notification..... | 3 |
| C. | QUALITY ASSURANCE | 3 |
| | C.1. QA Notification | 3 |
| | C.2. Red-line Authority..... | 3 |
| | C.3. Discrepancies..... | 4 |
| D. | TEST PERSONNEL | 4 |
| | D.1. Personnel Responsibilities | 4 |
| | D.2. Personnel Qualifications | 4 |
| | D.3. Required Personnel | 4 |
| E. | REQUIREMENTS..... | 5 |
| | E.1. Electrostatic Discharge Requirements | 5 |
| | E.2. Lifting Operation Requirements | 5 |
| | E.3. Hardware/Software Requirements | 5 |
| | E.4. Instrument Pretest Requirements..... | 6 |
| | E.5. Configuration Requirements | 8 |
| | E.6. Optional Non-flight Configurations | 8 |
| F. | REFERENCE DOCUMENTS..... | 9 |
| | F.1. Drawings..... | 9 |
| | F.2. Supporting documentation | 9 |
| | F.3. Additional Procedures..... | 10 |
| G. | OPERATIONS | 11 |
| | G.1. Pre-Operations Verifications..... | 11 |
| | G.2. Verify Purity of All Sources of Helium Gas | 11 |
| | G.3. Verify Configuration Requirements..... | 12 |
| | G.4. Verify Gas Module Configuration and Record Initial Conditions | 12 |
| | G.5. Verify SMD Configuration..... | 14 |
| | G.6. Set Up Data Acquisition System..... | 14 |
| | G.7. Transfer Pumping of Main Tank to Pump Module | 14 |
| | G.8. Install Stinger in LHSD | 16 |
| | G.9. Check Initial Pressure in Fill Line..... | 17 |
| | G.10. Raise Pressure in Fill Line..... | 17 |
| | G.11. Install Transfer Line Assembly | 17 |
| | G.12. Condition Transfer Line/Filter/Stinger Assembly | 18 |
| | G.13. Start Transfer | 19 |
| | G.14. Verify Start of Transfer | 20 |
| | G.15. Terminate Transfer | 20 |
| | G.16. Condition SMD Internal Fill Line | 22 |
| | G.17. Place Data Acquisition System in Standard Configuration | 22 |
| | G.18. Secure LHSD | 23 |
| | G.19. Verify Gas-Module Final Configuration..... | 24 |
| | G.20. Perform Final Closure of SV-13 and Condition Dewar Fill Cap Assembly..... | 25 |
| | G.21. Establish Final Configuration..... | 26 |
| H. | PROCEDURE COMPLETION | 27 |
| I. | APPENDIX 2 | 34 |

J. APPENDIX 3 – CONTINGENCY/EMERGENCY RESPONSES35

List of Abbreviations and Acronyms

| | | | |
|---------|---|---------|-----------------------------------|
| AG-x | Gauge x of Gas Module auxiliary section | MT | Main Tank |
| AMI | American Magnetics Inc. | MTVC | Main Tank Vent Cap |
| ATC | Advanced Technology Center | MTVC-G | Main Tank Vent Cap pressure gauge |
| APR-x | Pressure regulator x of Gas Module | MTVC-RV | Main Tank Vent Cap relief valve |
| AV-x | Valve x of Gas Module auxiliary section | MTVC-V | Main Tank Vent Cap valve |
| CG-x | Gauge x of portable helium pressurization source | NBP | Normal boiling point |
| CPR-x | Pressure regulator x of portable helium pressurization source | ONR | Office of Naval Research |
| CV-x | Valve x of portable helium pressurization source | PFCG | Fill Cap assembly pressure Gauge |
| CN [xx] | Data acquisition channel number | PFM | Pump equipment Flow Meter |
| DAS | Data Acquisition System | PG-x | Gauge x of Pump equipment |
| EFM | Exhaust gas Flow Meter | PM | Pump Module |
| EG-x | Gauge x of Gas Module exhaust section | psi | pounds per square inch |
| EH-x | Vent line heat exchanger in Gas Module | psig | pounds per square inch gauge |
| EM | Electrical Module | PTD | Payload Test Director |
| ERV-x | Relief valve of Gas Module exhaust section | PV-x | Valve x of the Pump equipment |
| EV-x | Valve number x of Gas Module exhaust section | QA | Quality Assurance |
| FCV | Fill Cap Valve | RAV-x | Remote Actuated Valve-x |
| FIST | Full Integrated System Test | RGA | Residual Gas Analyzer |
| GHe | Gaseous Helium | SMD | Science Mission Dewar |
| GM | Gas Module | STG | SMD Thruster vent pressure gauge |
| GP-B | Gravity Probe-B | SU | Stanford University |
| GSE | Ground Support Equipment | SV-x | SMD Valve number x |
| GT | Guard Tank | TG-x | Gauge x of Utility Turbo System |
| GTVC | Guard Tank Vent Cap | TV-x | Valve x of Utility Turbo System |
| GTVC-G | Guard Tank Vent Cap pressure gauge | UTS | Utility Turbo System |
| GTVC-RV | Guard Tank Vent Cap relief valve | Vac | Vacuum |
| GTVC-V | Guard Tank Vent Cap valve | VCP-x | Vent cap pressure gauge |
| GTV-G | Guard Tank vent pressure gauge | VCRV-x | Vent cap relief valve |
| GTV-RV | Guard Tank vent relief valve | VCV-x | Vent cap valve |
| GTV-V | Guard Tank vent valve | VDC | Volts Direct Current |
| KFxx | Quick connect o-ring vacuum flange (xx mm diameter) | VF-x | Liquid helium Fill line valve |
| LHe | Liquid Helium | VG-x | Gauge x of Vacuum Module |
| LHSD | Liquid Helium Supply Dewar | VM | Vacuum Module |
| LHV-x | Liquid Helium Supply Dewar valves | VV-x | Valve x of Vacuum Module |
| LLS | Liquid level sensor | VW-x | Valve x of Dewar Adapter |
| LM | Lockheed Martin Co. | | |

LIST OF SPECIFIC HEADING DEFINITIONS

Each type of alert message will precede the procedural step to which it applies

| |
|--|
| 1. NOTE: Used to indicate an operating procedure of such importance that it must be emphasized |
| 2. CAUTION: Used to identify hazards to equipment |
| 3. WARNING: Used to identify hazards to personnel |

A. SCOPE

This procedure describes the steps necessary to perform an external fill of the SMD Guard Tank with normal boiling point liquid helium. The steps include:

- Pre-cool SMD internal fill line from Guard Tank
- Pre-cool external transfer line
- Fill Guard Tank
- Terminate transfer

The procedure is for use when the Main Tank is Subatmospheric, and the Well is evacuated. Precooling of the internal fill line is accomplished using liquid from the Guard Tank itself. For this reason it is imperative that the Guard Tank liquid level be maintained at a value greater than 15%. The procedure can be performed when the Main Tank is being pumped or when it is unvented (i.e., SV-9 is closed).

The hazardous operations in this procedure are stinging and destinging the liquid helium supply dewars (LHSD).

B. SAFETY**B.1. Potential Hazards**

Personal injury and hardware damage can result during normal positioning, assembly and disassembly of hardware.

Liquid helium used in the SMD represents a hazardous material for the personnel involved in the operations. Cryogenic burns can be caused by contact with the cold liquid or gas, high pressures can result if boiling liquid or cold gas is confined without a vent path, and asphyxiation can result if the vent gas is allowed to accumulate.

The SMD Safety Compliance Assessment, document GPB-100153C and the Missile System Prelaunch Safety Package discuss the safety design, operating requirements and the hazard analysis of the SMD.

B.2. Mitigation of Hazards**B.2.1. Lifting hazards**

There are no lifting operations in this procedure

B.2.2. Cryogenic Hazards

In VAFB building 1610, the GP-B cryogenic team provides an oxygen deficiency monitor that alarms when the oxygen level is reduced to 19.5%. Additional temperature and pressure alarms, provided by the DAS, warn of potential over-pressure conditions. Emergency vent lines are installed over the four burst disks to direct any flow to an outside area.

Only authorized and trained personnel are allowed in VAFB facilities without escort. All personnel working on platforms at a height 30

inches or more off the floor are required to have an approved air tank (emergency breathing apparatus) within easy reach. Note that tank need not be kept available when working from ladder. In the unlikely event of a large LHe spill all employees have been instructed to evacuate the room and contact NASA and VAFB safety.

The following additional requirements apply to all personnel involved directly in cryogenic operations. Gloves that are impervious to liquid helium and liquid nitrogen are to be worn whenever the possibility of splashing or impingement of high-velocity cryogenics exists or when handling equipment that has been cooled to cryogenic temperatures. Protective clothing, non-absorbent shoes and full-face shields with goggles/glasses are to be worn whenever the possibility of splashing cryogenics exists

B.2.3. Other Hazards

When appropriate, tools or other items used with the potential to damage the space vehicle shall be tethered

B.3. Mishap Notification

B.3.1. Injury

In case of any injury or illness requiring emergency medical treatment **DIAL 911**.

B.3.2. Hardware Mishap

In case of an accident, incident, or mishap, notification is to proceed per the procedures outlined in Lockheed Martin Engineering Memorandum EM SYS229 and Stanford University GP-B P0879. Additionally, VAFB NASA Safety and 30th Space Wing Safety will be notified as required.

B.3.3. Contingency Response

Responses to contingencies/emergency (e.g., power failure) are listed in Appendix 3.

C. QUALITY ASSURANCE

C.1. QA Notification

The NASA program and the NASA safety representative and SU QA shall be notified 24 hours prior to the start of this procedure. Upon completion of this procedure, the QE Manager will certify his/her concurrence that the effort was performed and accomplished in accordance with the prescribed instructions by signing and dating in the designated place(s) in this document.

C.2. Red-line Authority

Authority to red-line (make minor changes during execution) this procedure is given solely to the TD or his designate and shall be approved by the QA Representative. Additionally, approval by the Payload Technical Manager shall

be required, if in the judgment of the TD or QA Representative, experiment functionality may be affected. Within hazardous portions of the procedure all steps shall be worked in sequence. Out-of-sequence work or redlines shall be approved by NASA Safety prior to their performance.

C.3. **Discrepancies**

A Quality Assurance Representative designated by D. Ross shall review any discrepancy noted during this procedure, and approve its disposition. Discrepancies will be recorded in a D-log or a DR per Quality Plan P0108. Any time a procedure calls for verification of a specific configuration and that configuration is not the current configuration, it represents a discrepancy of one of three types. These types are to be dealt with as described below.

1. If the discrepancy has minimal effect on procedure functionality (such as the state of a valve that is irrelevant to performance of the procedure) it shall be documented in the procedure, together with the resolution. Redlines to procedures are included in this category.
2. If the discrepancy is minor and affects procedure functionality but not flight hardware fit or function, it shall be recorded in the D-log. Resolution shall be in consultation with the PTD and approved by the QA representative.
3. All critical and major discrepancies, those that effect flight hardware fit or functions, shall be documented in a D-log and also in a Discrepancy Report, per P0108.

D. **TEST PERSONNEL**

D.1. **Personnel Responsibilities**

The performance of this procedure requires a minimum complement of personnel as determined by the Test Director. The person performing the operations (Test Director or Test Engineer) is to sign the “Completed by” sign-off. Any other qualified person or QA person who can attest to the successful performance of this procedure may sign the “Witnessed by” sign-off. The Test Director will perform Pre-Test and Post-Test Briefings in accordance with P0875 “GP-B Maintenance and Testing at all Facilities.” Checklists will be used as directed by P0875

D.2. **Personnel Qualifications**

The Test Director must have a detailed understanding of all procedures and facility operations and experience in all of the SMD operations. Test Engineers must have SMD Cryogenic operations experience and an understanding of the operations and procedures used for the cryogenic servicing/maintenance of the Dewar.

D.3. **Required Personnel**

The following personnel are essential to the accomplishment of this procedure:

| <u>FUNCTIONAL TITLE</u> | <u>NUMBER</u> | <u>AFFILIATION</u> |
|-------------------------|---------------|--------------------|
|-------------------------|---------------|--------------------|

| | | |
|-----------------------------|---|----------------|
| Test Director/Test Engineer | 1 | Stanford |
| GP-B Quality Assurance | 1 | Stanford |
| NASA Safety Rep | 1 | SFAO or ANALEX |

E. REQUIREMENTS

E.1. Electrostatic Discharge Requirements

When working on the space vehicle, proper ESD protection is required. Wrist Straps will be checked on an appropriate calibrated checker prior to use.

E.2. Lifting Operation Requirements

There are no lifting operations in this procedure

E.3. Hardware/Software Requirements

E.3.1. Commercial Test Equipment

No commercial test equipment is required for this operation.

E.3.2. Ground Support Equipment

The Ground Support Equipment includes the Gas Module, Pump Module, the Electrical Module. The Gas Module provides the capability to configure vent paths, read pressures and flow rates, and pump and backfill vent lines. The Pump Module provides greater pumping capacity than the Gas Module, together with additional flow metering capabilities. The vent output of the Gas Module flows through the Pump Module. The Electrical Module contains the instruments listed in Table 1, and provides remote control of valves in the Gas Module, Pump Module, and SMD.

This procedure calls for use of hardware located in the Gas, Pump and Electrical Modules.

E.3.3. Computers and Software:

The Data Acquisition System (DAS) and data acquisition software are required for this procedure. The DAS reads and displays pressures, temperatures, and flow rates and monitors critical parameters. No additional computers or software are required.

E.3.4. Additional Test Equipment

| <i>Description</i> | <i>Manufacturer</i> | <i>Model</i> |
|-----------------------------------|---------------------|--------------|
| AMI Level Sensor Readout for LHSD | AMI | 110 |

E.3.5. Additional Hardware

| <i>Description</i> | <i>Manufacturer</i> | <i>Model</i> |
|-----------------------------|---------------------|--------------|
| Filter Line assembly | LMMS | 5833827 |
| Liquid He Transfer Line | LMMS | 5833804 |
| Liquid He Stinger | LMMS | 5833803 |
| GHe supply fittings to LHSD | N/A | N/A |

E.3.6. Additional Hardware

1. Four liter liquid nitrogen thermos

E.3.7. Tools

| <i>Description</i> |
|---|
| Torque Wrench, 1-1/4-in socket, 60 in-lb S/N #: _____ Cal Due Date: _____ |

E.3.8. Personnel Protective Equipment

1. Cryogenic safety gloves and apron
2. Face Shield
3. Goggles/glasses
4. Non-absorbent shoes
5. Rubber Gloves (if ethanol is used)

E.3.9. Expendables

| WARNING |
|---|
| Ethanol is highly flammable and vapor/air mixtures are Explosive. Exposure hazards include: Inhalation (headache/fatigue), skin (dryness, eyes (redness/pain/burning)) |

| <i>Description</i> | <i>Quantity</i> | <i>Mfr./Part No.</i> |
|-----------------------------------|-----------------|---------------------------------------|
| Ethanol | AR | N/A |
| 99.999% pure gaseous helium | AR | N/A |
| Vacuum Grease | AR | Apeizon or Dow Corning High Vacuum |
| Liter Liquid Helium Storage Dewar | AR | SU or commercial |
| Tie wraps - large size | AR | N/A |

E.4. **Instrument Pretest Requirements**

The GSE instruments required to perform this procedure are listed in Table 1, together with their serial numbers, where available. Instruments that are required to have current calibrations are indicated in the Cal-Required column. Instruments that do not require calibration are those not used to verify performance requirements and are not connected to flight instrumentation. The status column is to be filled in with the due date of the instrument calibration sticker and verified to be in calibration by QE or QE designee. Serial numbers are to be updated as appropriate.

Table 1. Required Instrumentation and Calibration Status

| No. | Location | Description | Name | Serial No. | Cal Required | Status Cal due date |
|------------|-----------------|---|------------------|-------------------|---------------------|----------------------------|
| 1 | DAS | Power Supply, H-P 6627A | A1, A2, A3, A4 | 3452A01975 | Yes | |
| 2 | DAS | Power Supply, H-P 6627A | B1, B2, B3, B4 | 3452A01956 | Yes | |
| 3 | DAS | Data Acquisition/Control Unit H-P 3497A | - | 2936A245539 | No | - |
| 4 | DAS | Digital Multimeter H-P 3458A | - | 2823A15047 | Yes | |
| 5 | EM | Vacuum Gauge Controller Granville-Phillips Model 316 | EG-1a, -1b | 2827 | No | - |
| 6 | EM | Vacuum Gauge Controller Granville-Phillips Model 316 | AG-2a, -2b | 2826 | No | - |
| 7 | EM | Vacuum Gauge Controller Granville-Phillips Model 316 | EG-3 | 2828 | No | - |
| 8 | EM | MKS PDR-C-2C | EG-2, FCG | 92022108A | No | - |
| 9 | EM | Flow meter – Matheson 8170 | EFM-1 | 96186 | No | - |
| 10 | EM | Flow meter totalizer Matheson 8124 | EFM-1 | 96174 | No | - |
| 11 | EM | Liquid Helium Level Controller American Magnetics, Inc. 136 | LLS Main Tank | 96-409-11 | No | - |
| 12 | EM | Liquid Helium Level Controller American Magnetics, Inc. 136 | LLS Guard Tank | 96-409-10 | No | - |
| 13 | EM | Liquid Helium Level Controller American Magnetics, Inc. 136 | LLS Well | 96-409-9 | No | - |
| 14 | EM | Liquid Helium Level Controller American Magnetics, Inc. 136 | LLS Axial Lock | 96-409-12 | No | - |
| 15 | EM | Pressure Controller – MKS 152F-92 | EV-7a, -7b | 96203410A | No | - |
| 16 | EM | Power Supply HP 6038A | H08D Tank Heater | 96023407A | Yes | |
| 17 | EM | Power Supply HP 6038A | H09D Tank Heater | 3511A-13332 | Yes | |
| 18 | EM | Power Supply HP 6038A | RAV Power Supply | 3329A-12486 | Yes | |
| 19 | EM | Vac Ion Pump power supply Varian 929-0910, Minivac | SIP | 5004N | No | - |
| 20 | EM | Flow meter totalizer Veeder-Root | PFM-1 | 576013-716 | No | - |
| 21 | GM | Pressure Gauge, Heise | AG-1 | CC-122077 | No | - |
| 22 | GM | Pressure Gauge, Marshall Town | AG-3 | N/A | No | - |
| 23 | GM | Main Tank Heat Exchanger: a) Thermocouple, b) Current meter, c) Temperature set point controller | EH-1 | C-19950 | No | - |
| 24 | GM | Guard Tank Heat Exchanger: a) Thermocouple, b) Current meter, c) Temperature set point controller | EH-2 | C-09920 | No | - |
| 25 | VM | Vacuum Gauge readout, Granville-Phillips 316 | VG-3 VG-4 | 2878 | No | - |
| 26 | VM | Vacuum Gauge readout, | VG-1, VG-2 | 96021521 | No | - |

| No. | Location | Description | Name | Serial No. | Cal Required | Status Cal due date |
|------------|-----------------|------------------------|-------------|-------------------|---------------------|--------------------------------|
| | | Granville-Phillips 360 | VG-5 | | | |

E.5. Configuration Requirements

E.5.1. Main Tank

Liquid in the Main Tank is subatmospheric. If the Main Tank is not closed out at SV-9, the actuator control valve for EV-9 (located on the Gas Module, this valve switches the state that EV-9 defaults to, should a power failure occur) should be placed in the “Subatm He.” position

E.5.2. Guard Tank

The Guard-Tank liquid level (Guard Tank LLS-B) must be greater than 15% to adequately precool the internal fill line.

E.5.3. Well

The Well is evacuated.

E.5.4. SMD Vacuum Shell

The Vacuum Shell pressure must be less than 5×10^{-5} torr. Document No. P1015, *Connect Vacuum Module to SMD*, contains the procedure for connecting to and pumping on the SMD vacuum shell.

E.5.5. Alarm System

1. The DAS alarm system must be enabled and contain the following alarm set-points:
 - a. Top of lead bag temperature set (CN 175) at $T \leq 2.2$ K.
 - b. Top of lead bag temperature set (CN 178) at $T \leq 2.2$ K.
 - c. Relative Guard Tank Pressure (CN 46) set at $\Delta P \geq 0.3$ torr.
2. The watchdog timer must be enabled

E.5.6. GSE and Non-flight Hardware

1. The Main Tank vent line must be connected to the Gas Module with a vacuum insulated line. Document No. P1004, *Connect Main Tank Vent Line to Gas Module – Main Tank at NBP*, contains the procedures for connecting the Main Tank vent line.
2. The Guard Tank vent line must be connected to the Gas Module with a vacuum insulated line (P/N 5833813). Document No. P1005, *Connect Guard Tank Vent Line to Gas Module*, contains the procedures for connecting the Guard Tank vent line.
3. The Fill Cap Assembly must be installed at SV-13 (Figure 3)
4. The ion-pump magnet must be installed.

E.6. Optional Non-flight Configurations

The following non-flight modifications of the basic SMD and optional GSE configurations are incidental to the performance of this procedure. Any combination represents an acceptable configuration.

1. The SMD maybe installed in its transportation and test fixture.
2. The Vacuum shell pump out port at SV-14 may be connected to the Vacuum Module (P/N 5833816) via a 2-in valve and pumping line, with the valve in either the closed position or in the open position. The Vacuum Module pump may be off, actively pumping the pumping line up to a closed SV-14, or actively pumping the vacuum shell.

F. REFERENCE DOCUMENTS

F.1. Drawings

| <i>Drawing No.</i> | <i>Title</i> |
|--------------------|------------------------------|
| LMMS-5833394 | Instrumentation Installation |

F.2. Supporting documentation

| <i>Document No.</i> | <i>Title</i> |
|---------------------|---|
| LMMC-5835031 | GP-B Magnetic Control Plan |
| GPB-100153C | SMD Safety Compliance Assessment |
| LM/P479945 | Missile System Prelaunch Safety Package |
| SU/GP-B P0141 | FIST Emergency Procedures |
| LMSC-P088357 | Science Mission Dewar Critical Design Review |
| SU/GP-B P0108 | Quality Plan |
| LMMS GPB-100333 | Science Mission Dewar Failure Effects and Causes Analysis |
| SU/GP-B P059 | GP-B Contamination Control Plan |
| EM SYS229 | Accident/Mishap/Incident Notification Process |
| EWR 127-1 | Eastern and Western Range Safety Requirements |
| KHB 1710.2 rev E | Kennedy Space Center Safety Practices Handbook |

F.3. **Additional Procedures**

| <i>Document No.</i> | <i>Title</i> |
|----------------------------|--|
| SU/GP-B P0879 | Accident/Incident/Mishap Notification Process |
| SU/GP-B P1015 | Connect Vacuum Module to SMD |
| SU/GP-B P0875 | GP-B Maintenance and Testing at all Facilities |

Operation Number: _____

Date Initiated: _____

Time Initiated: _____

G. OPERATIONS

G.1. Pre-Operations Verifications

- o Verify SU QA notified.
Record: Individual notified _____,
Date/time ____/____.
- o Verify NASA program representative notified.
Record: Individual notified _____,
- o Verify NASA safety representative notified and concurrence has been given to proceed.
Record: Individual notified _____
Date/Time: _____,
- o Record calibration due dates in Table 1 (Sections. E.3.4, E.4)
- o Persons actually performing this procedure should list their names in Sec D.3.
- o Verify completion of the pre-operations checklist (Appendix 1).
- o Verify proper operation of GP-B Cryogenic Team oxygen monitor
- o Verify availability and functioning of emergency shower
- o Verify that the Spacecraft is powered up, arming plug P222 is installed, and spacecraft operations personnel are prepared to command RAV-2 when requested.
- o If appropriate, verify that the master procedure calling this procedure is current. Enter calling procedure number: _____, and Op. order no.: _____

G.2. Verify Purity of All Sources of Helium Gas

G.2.1. Record serial number on helium bottle/s.

1. _____ 2. _____ 3. _____
4. _____ 5. _____ 6. _____

Verify helium bottle/s have been tested for purity and record Op. Number.

Op. Number: _____

QA Witness: _____

G.3. Verify Configuration Requirements

- G.3.1. Verify Main Tank vent line connected to Gas Module. If not perform procedure P1004, *Connect Main Tank Vent Line to Gas Module – Main Tank Subatmospheric*, to connect Main Tank vent.
- G.3.2. Verify Guard Tank vent line connected to Gas Module. If not, perform procedure P1005, *Connect Guard Tank Vent Line to Gas Module*, to connect Guard Tank vent.
- G.3.3. Verify Fill Cap Assembly installed at SV-13.
- G.3.4. Verify ion-pump magnet installed.
- G.3.5. Verify Main Tank subatmospheric. Record Main Tank temperature, CN [09] _____ K and verify < 4.2 K.
- G.3.6. Verify DAS alarm system enabled and record set points.
1. **Top of lead bag temperature** – verify CN [175] on DAS alarm list and set to alarm at $T \leq 2.2$ K. Record set point. _____ K
 2. **Top of lead bag temperature** – verify CN [178] on DAS alarm list and set to alarm at $T \leq 2.2$ K. Record set point. _____ K
 3. **Relative Guard Tank Pressure** – verify CN [46] on DAS alarm list and set to alarm at $\Delta P \geq 1$ torr. Record set point. _____ torr
- G.3.7. Ensure DAS watchdog timer and alarm enabled.
- G.3.8. Ensure liquid-level alarms enabled and record set points.
1. **Main Tank** – ensure alarm set $\geq 20\%$. Record set point. _____ %
 2. **Guard Tank** – ensure liquid-level alarm set $\geq 20\%$. Record set point. _____ %
- G.3.9. If Guard Tank is expected to drop below 20% during precool, switch Guard Tank level alarm off

G.4. Verify Gas Module Configuration and Record Initial Conditions

- G.4.1. Verify valve states are as indicated in following Table. Record config. by checking appropriate box, then verify corresponding valve states.

-
- o Main Tank pumped by Gas Module (AP-1)
 1. Verify SV-9 open.
 2. Verify open EV-7a/b, EV-10, EV-13, EV-17.
 3. Verify all other EV valves closed.
 4. Verify AP-1 on.
-

-
5. Verify AV-6 open.
 6. Verify all other AV valves closed.
 7. Verify open PV-2 and PV-4.
 8. Verify closed PV-1, PV-3, PV-5 and PV-6.
 9. Record position of EV-7a: _____ % EV-7b _____ %
 10. Verify Actuator Control Valve for EV-9 in “Subatm He” position.
-

o Main Tank pumped by Pump Module (PP-1/2)

11. Verify SV-9 open.
 12. Verify open EV-4, EV-7a/b, EV-10, EV-13, EV-17, EV-21/22.
 13. Verify all other EV valves closed.
 14. Verify all AV valves closed.
 15. Verify PP-1/2 on.
 16. Verify open PV-1, PV-2, PV-3, and PV-4.
 17. Close/verify closed PV-5 and PV-6.
 18. Record position of EV-7a: _____ % EV-7b _____ %
 19. Verify Actuator Control Valve for EV-9 in “Subatm He” position.
-

o Main Tank not pumped (SV-9 closed)e.

20. Verify SV-9 closed.
 21. Verify EV-13, EV-16 open.
 22. Verify all other EV valves closed.
 23. Verify all AV valves closed.
 24. Verify open PV-2 and PV-4.
 25. Verify closed PV-1, PV-3, PV-5 and PV-6.
-

G.4.2. Verify Vacuum Shell Pressure < 5×10^{-5} torr.

1. Turn on Vac-ion pump and record time of day _____
2. Use DAS [Monitor Data] for CN 99.
3. When value is steady, record pressure (IP) _____ torr. If pressure is above 5×10^{-5} torr, turn off Vac-ion pump and perform procedure P1015, *Connection of High Vacuum Pumping Module*, to connect Vacuum Module and pump out SMD vacuum shell.
4. Exit [Monitor Data] and collect data with [Set Data Interval] to 5 min.
5. When data cycle is complete, turn off Vac-ion pump.

G.4.3. Record initial liquid helium levels.

1. **Main Tank** _____ %
2. **Guard Tank** – verify level $\geq 15\%$ to precool internal transfer line. _____ %

G.4.4. Record initial temperatures

1. Top of Lead Bag CN [175] _____ K.
2. Top of Lead Bag CN [178] _____ K.

G.4.5. Record pressures where appropriate.

1. Guard Tank (GTV-G): _____ torr (relative to atm.).
2. Main Tank (EG-2): _____ torr.
3. Main Tank (EG-1a) _____ torr.
4. Main Tank (STG) CN [49] _____ torr diff.

G.4.6. Record Fill Cap Assembly pressure and verify that it reads > 760 torr.
Fill Cap Assembly pressure (PFCG): _____ torr.

G.4.7. Record Vacuum Module Pressure (if connected): (VG-1): _____ torr.

Section Complete Quality _____

G.5. **Verify SMD Configuration**

G.5.1. Using the RAV log book verify that the dewar's internal valves are in the following positions. If not, investigate to ensure previous RAV operations properly recorded. If necessary, note resolution in D-log.

1. **Closed:** RAV-1, RAV-2, RAV-5, RAV-6A, and RAV-7.
2. **Record** state of RAV-3: _____, and RAV-6B: _____.

G.5.2. Verify that SMD external valves are in the following positions.
Closed: SV-13 and FCV.G.6. **Set Up Data Acquisition System**

G.6.1. Verify DAS configuration set to 4ae.

G.6.2. Set DAS to fast scan mode using [other menus], [data config], [fast scan]

G.6.3. Start "Special Data Cycle" by using [Other Menus] + [Special Data Col] + [Select CN [01], [09], [28], [42], and [46]] + [Init. Collectn] + [Enter] (=use default file)

G.6.4. Set Guard Tank Liquid Level Sensor sampling interval to 1 min.

G.6.5. Ensure printer is displaying special Data Cycle data.

Section Complete Quality _____

G.7. **Transfer Pumping of Main Tank to Pump Module**

Note:

This operation is to be performed if Main Tank is being pumped by Gas Module pump (AP-1) and it is necessary to transfer pumping to the Pump Module in order to allow AP-1 to be used for conditioning the transfer line, etc. It is assumed that the plumbing between the Pump Module the Gas Module has been successfully leak checked.

- o Main Tank is pumped by AP-1, perform this section
 - o Main Tank is already pumped by Pump Module or is closed out, skip this section
 - o Main Tank is not vented (SV-9 closed), skip this section.
- G.7.1. Verify open PV-2 and PV-4.
- G.7.2. Verify closed PV-1, PV-3, PV-5, and PV-6.
- G.7.3. Initiate the Pump Module
1. Turn on/verify turned on water cooling of pump module.
 - a. Check oil level in Vane Pump (PP-2), record time _____ and initial _____.
 - b. If oil level is low add new oil to PP-2 per specification in Pump Module Manual.
 2. Verify closed EV-4, EV-14, and EV-21/22.
 3. Turn on rotary vane pump PP-2.
 4. Open PV-1.
 5. Once pressure PG-1 has come to equilibrium (< 1 torr), turn on roots pump PP-1 and verify PG-1 < 15 mtorr.
 6. Record PG-1 _____ mtorr.
 7. Record pressure at AG-2b _____ torr.
- G.7.4. Transfer pumping to Pump Module.
1. Verify closed AV-8.
 2. Open EV-21 and EV-4.
 3. Close AV-6.
 4. Open PV-3.
 5. Record time of day : _____
- G.7.5. Verify valve configuration:

| | |
|---------------|---|
| Open | EV-4, EV-10, EV-17, EV-13, EV-21 EV-7a/b (A/R) PV-1, PV-2, PV-3, PV-4 |
| Closed | All other EV, PV valves |

| | |
|--|---------------|
| | All AV valves |
|--|---------------|

G.8. Install Stinger in LHSD

WARNING:

A hazardous operation is about to begin. In the following steps cold helium gas will be expelled from the stinger and transfer lines. The operator performing the operation must wear a face shield with goggles/glasses, apron, non-absorbent shoes, and cryogenic gloves. Failure to comply may result in personal injury.

Note:

Use appropriate extension for the LHSD being used and clean all O-rings and mating surfaces. See Fig. 5 for transfer plumbing configuration.

- G.8.1. Turn on the amber warning light and make a PA announcement stating, "Attention all personnel, the GP-B program is now performing a hazardous cryogenic operation". Verify that the area is clear of nonessential personnel.
- G.8.2. Establish a controlled area of 15 feet.
- G.8.3. Reduce the pressure in the liquid helium supply to < 1.0 psig by opening the LHSD vent valve LHV-1.
- G.8.4. Open valve VF-1 (Liquid withdrawal valve) on the stinger
- G.8.5. Slowly insert the stinger into the LHSD while allowing it to be purged.
- G.8.6. Close valve VF-1 just as cold gas is expelled from stinger.
- G.8.7. Close the primary (low-pressure) relief valve on the LHSD (LHV-2).
- G.8.8. Increase LHSD ullage pressure to 8 to 10 psig by attaching an external source of GHe to ullage inlet (LHV-1, labeled VENT on LHSD) per the following:
 - 1. Attach a GHe hose to the VENT outlet of the LHSD while purging the hose and the VENT outlet.
 - 2. Adjust pressure regulator to obtain 8 to 10 psig LHSD driving pressure.
- G.8.9. Record LHSD data:
 - 1. Date / time _____
 - 2. Liquid level _____ %
 - 3. LHSD serial number _____
- G.8.10. Request PA announcement that the hazardous operation is now complete.
- G.8.11. Ensure area operation light is returned to green.
- G.8.12. Disband controlled area.

NOTE

The hazardous operation is now complete.

G.9. Check Initial Pressure in Fill Line

- G.9.1. Install a pumping line between valve FCV on the Fill Cap Assembly and the Access Port #1 of the Auxiliary gas section.
- G.9.2. Turn on/verify on pump AP-1.
- G.9.3. Open AV-8 and AV-3.
- G.9.4. Open valve FCV and evacuate to 20 mtorr as measured at AG-2.
- G.9.5. Close AV-8 and FCV.
- G.9.6. Once the pressure in the Fill Cap Assembly has stabilized, record Fill Cap Assembly pressure (PFCG): _____ torr.
- G.9.7. Open valve SV-13 to bring Fill Cap Assembly up to SMD Fill line pressure and record PFCG _____ torr.

Section Complete Quality _____

G.10. Raise Pressure in Fill Line

- G.10.1. Confirm that operations personnel are ready to operate RAV-2.
- G.10.2. Open RAV-2 as follows:
 - 1. Request spacecraft operations personnel to open RAV-2 and record time of day: _____.
 - 2. Have spacecraft operations personnel confirm valve has opened.
 - 3. When convenient, record operation in RAV log book.
- G.10.3. Verify that the Fill Cap Assembly pressure rises to the Dewar Guard Tank pressure.
 - 1. Record Fill line pressure (PFCG): _____ torr.
 - 2. Record Guard Tank Pressure (GTV-G) _____ torr diff.

Section Complete Quality _____

G.11. Install Transfer Line Assembly**Note:**

In the following steps the fill line is connected from the LHSD stinger at VF-1 to the SMD. Two transfer lines are available for use. One has an integrated filter and connects directly to bayonet B3 at the dewar. The other has a separate filter that is first installed at bayonet B3, after which the fill line is connected to the filter.

- G.11.1. Remove the Fill Cap Assembly.

G.11.2. If using Transfer Line Filter, install it in Dewar Fill Bayonet B3.

G.11.3. Install Transfer Line as follows:

CAUTION:

Be sure to provide adequate support to the Fill Line by the use of support stands or other means so as to not apply excessive load on the Filter Assembly and Stinger. Failure to comply may result in equipment damage.

1. Mate the Fill Line (P/N 5833804) with the LHSD Stinger at VF-1.
2. Mate VF-2 end of transfer line with Transfer Line Filter or B3 as appropriate.
3. Ensure VF-2 and relief valve stems pointed upward.
4. Close / verify closed VF-3.
5. Connect a low-impedance facility vent line to the KF fitting at VF-3.

Section Complete Quality _____

G.12. Condition Transfer Line/Filter/Stinger Assembly

G.12.1. Configure Pumping Line as follows:

1. Ensure flexible pumping line mated to Access Port #1 of Auxiliary Gas section.
2. Mate other end to outlet of VF-2.

G.12.2. Evacuate Transfer Line:

1. Close/verify closed VF-3.
2. Open valve VF-2.
3. Open/verify open AV-3.
4. Open AV-8.
5. Close AV-8 when pressure reaches less than 50 mtorr as read on gauge AG-2.

G.12.3. Backfill Transfer Line:

1. Open AV-1.
2. Open AV-9 until pressure reaches 0.5 psig as read on gauge AG-1 and then Close AV-9.
3. Close AV-1.

G.12.4. Evacuate Transfer Line (second time):

1. Open AV-8.
2. Close AV-8 when pressure reaches less than 50 mtorr as read on

gauge AG-2.

G.12.5. Backfill Transfer Line (second time):

1. Open AV-1.
2. Open AV-9 until pressure reaches 0.5 psig as read on gauge AG-1 and then Close AV-9.
3. Close AV-1.

Section Complete Quality_____

G.13. **Start Transfer**

Note:

This section starts the transfer by pre-cooling the SMD internal Fill Line by pushing liquid up from the Guard Tank.

CAUTION

Transfer startup is a critical operation. All potentially interfering operations must be suspended. A qualified test director/engineer must be assigned to monitor temperatures at Station 200 and the top of the lead bag during precool and initial startup of transfer. Failure to comply may result in equipment damage

- G.13.1. Ensure plastic sheeting placed appropriately on the Guard Tank vent to ensure no condensation falls onto the Space Vehicle
- G.13.2. Turn on Guard Tank vent line heat exchanger (EH-2).
- G.13.3. Ensure VF-3 closed.
- G.13.4. Ensure VF-2 open.
- G.13.5. Open SV-13.
- G.13.6. Record Guard Tank pressure (GTV-G): _____ torr (relative to atm).
- G.13.7. Turn on power supply for Guard-Tank heater (H-3D or H-4D)
 1. Set power supply current limit to 0.07 amps.
 2. Set to 50 VDC and record: V _____Vdc and I _____A.
- G.13.8. Open VF-3.
- G.13.9. Close EV-13
- G.13.10. Enter comment to DAS "Start Precool."

Note:

Precool internal fill line until a air condensation is evident at VF-3 and Fill Valve (SV-13) temperature CN [42], is < 75 K. If the initial Guard Tank level is < 25% attempting to cool SV-13 below 75 K may result in depletion of the Guard Tank.

- G.13.11. When a air condensation is evident at VF-3 and Fill Valve (SV-13) temperature T-24D, CN [42], is < 75 K,

1. Power off Guard Tank heaters.
2. Close SV-13.
3. Immediately open VF-1.

G.13.12. Open EV-13

G.13.13. When heavy air condensation is evident at VF-3:

1. Close VF-2 and immediately
2. Open SV-13.

G.13.14. Open EV-6 and EV-18.

G.13.15. Close VF-3 when it thaws out.

Section Complete Quality_____

G.14. **Verify Start of Transfer**

CAUTION

Except for the startup transient, do not exceed 100 LL/hr transfer rate as read on PFM-1 (scale B) as this exceeds the capacity of the vent line heat exchanger (EH-2) in the Gas Module. Failure to comply may result in equipment damage.

G.14.1. Verify flow meter (PFM-1) reading of ~100 liquid liters/hour.

PFM-1 (scale B) reading: _____

Start Time: _____

G.14.2. Record LHe level of LHSD: _____ %

G.14.3. Input comment to DAS “Starting External Fill of Guard Tank”.

G.14.4. Record all fill data on the attached data sheet every 15 minutes.

G.14.5. Adjust LHSD pressure:

1. Close pressurization valve at the LHSD and adjust the gas supply pressure regulator to the desired pressure not to exceed 10 psig.
2. Reopen pressurization valve at the LHSD.

G.14.6. Select desired Guard Tank fill level _____ %

G.14.7. When Guard Tank is at desired level, record Guard Tank level and proceed to terminate transfer.

Guard Tank Level (LL-5D or LL-6D) _____ %

Section Complete Quality_____

G.15. **Terminate Transfer**

G.15.1. Stop the flow of liquid helium:

1. Close VF-1 and record time of day _____.

2. Close SV-13 and torque to 60 in-lbs \pm 5 in-lbs
3. **Immediately open** VF-2.
4. Open VF-3
5. Close EV-6 and EV-18.

G.15.2. Enter comment to DAS “Stop Transfer.”

G.15.3. Remove the pumping and vent lines at valve VF-3.

G.15.4. Remove the Transfer and Filter Lines from the Dewar fill bayonet B3 and immediately install the Fill Cap Assembly.

Section Complete Quality_____

G.16. Condition SMD Internal Fill Line

- G.16.1. Connect a pumping line between the Fill Cap Assembly at valve FCV and the Auxiliary Gas Section access port no. 1.
- G.16.2. Ensure valves AV-1 and AV-9 closed.
- G.16.3. Open AV-8 and AV-3.
- G.16.4. Open valve FCV and evacuate Fill Cap Assembly to <25 mtorr measured at AG-2B.
- G.16.5. Close FCV.
- G.16.6. Open SV-13.
- G.16.7. Close RAV-2 (GT fill valve) by performing the following operations:

Note:

Relief of fill line is through Fill Cap Assembly

- 1. Request spacecraft operations personnel to close RAV-2 and record time of day: _____.
 - 2. When convenient, record operation in RAV logbook.
- G.16.8. Open FCV and evacuate the Dewar fill line to < 25 mtorr as measured at AG-2b.
 - G.16.9. Record pressure AG-2b _____ torr.
 - G.16.10. Close SV-13 and torque to 60 +/- 5 in-lbs.
 - G.16.11. Close FCV.
 - G.16.12. Close AV-8.
 - G.16.13. Open AV-1.
 - G.16.14. Open AV-9 until pressure reaches 1.5 psig as read on gauge AG-1 and then close AV-9.
 - G.16.15. Close AV-1.
 - G.16.16. Monitor the pressure in the Fill Cap Assembly PFC for 15 minutes to be assured that no gas is leaking into the Fill Cap Assembly (i.e. it maintains vacuum) and record:
 - Time of day _____. PFCG pressure: _____ torr.
 - Time of day _____. PFCG pressure: _____ torr.

Section Complete Quality_____

G.17. Place Data Acquisition System in Standard Configuration

- G.17.1. Input comment to DAS "Completed External fill of Guard Tank".
- G.17.2. Stop Special Data Cycle by using [Other Menu] + [Special Data Col] + [Stop Data Col].

- G.17.3. Set DAS to normal scan using [other menus], [data config], [normal scan].
- G.17.4. Set DAS data cycle interval to 15 minutes.
- G.17.5. Set Guard Tank liquid level sampling interval to 10 minutes.
- G.17.6. Ensure Main Tank liquid level sampling interval set to 10 minutes.
- G.17.7. Ensure the Vac-ion pump is off.
- G.17.8. Ensure all RAV operations recorded in log book.
- G.17.9. Ensure DAS alarm enabled and record set points if changed
- o Thermal conditions substantially unchanged, alarm set points for Station 200 and lead bag are unchanged and set to alarm.
 - o Thermal conditions substantially changed, temperature alarm points reset as follows:
 - a. Top of Lead Bag set point [CN 175] _____ K (≤ 6.0 K)
 - b. Top of Lead Bag set point [CN 178] _____ K (≤ 6.0 K)
- G.17.10. Ensure liquid level sensor alarms enabled on Main Tank, Guard Tank, and Well and record set points if changed.
1. Main Tank Level Set Point _____%
 2. Guard Tank Set Point _____%
- G.17.11. Ensure Guard Tank pressure on DAS alarm list and set to alarm at 1 torr differential.
- G.17.12. Ensure DAS watchdog timer and alarm enabled.

Section Complete Quality _____

G.18. **Secure LHSD**

WARNING:

In the following steps cold helium gas will be expelled from the LHSD vent (LHV-1). In addition, removal of the stinger involves handling of a cold surface. Both the cold gas and the stinger surface are capable of quickly causing severe frostbite. The operator performing the operation must ensure that the cold gas is directed away from all personnel and must wear a face shield with goggles/glasses, apron, non-absorbent shoes, and cryogenic gloves. Failure to comply may result in personal injury.

- G.18.1. Verify safety clear area and amber light still in operation
- G.18.2. Shut off the GHe supply used to pressurize the LHSD.
- G.18.3. Close LHV-1 (VENT outlet valve of the LHSD), and disconnect the pressurization line.

- G.18.4. Crack open LHV-1 and LHV-2, the primary (low-pressure) relief valve, to allow the LHSD to depressurize.
- G.18.5. When the primary relief valve at LHV-2 stops venting, completely open LHV-1 and carefully remove the stinger from the LHSD and close the stinger access ball valve.
- G.18.6. Close LHV-1 (the VENT outlet valve).
- G.18.7. Ensure that LHV-2, the primary (low-pressure) relief valve, is fully open

NOTE

The hazardous operations are now complete

- G.18.8. Disband controlled area.
- G.18.9. Turn off the amber warning light and make a PA announcement stating, "Attention all personnel, the GP-B program has completed the hazardous cryogenic operation".

Section Complete Quality _____

G.19. Verify Gas-Module Final Configuration

- G.19.1. Verify valve states are as indicated in following Table. Record configuration by checking appropriate box, then verify corresponding valve states.

-
- o Main Tank pumped by Pump Module (PP-1/2)
 1. Verify SV-9 open.
 2. Verify open EV-4, EV-7a/b, EV-10, EV-13, EV-17, EV-21.
 3. Verify all other EV valves closed.
 4. Verify all AV valves closed.
 5. Verify PP-1/2 on.
 6. Verify open PV-1, PV-2, PV-3, and PV-4.
 7. Close/verify closed PV-5 and PV-6.
-
- o Main Tank not pumped (SV-9 closed).
 8. Verify SV-9 closed.
 9. Verify EV-16, and EV-13 open.
 10. Verify all other EV valves closed.
 11. Verify all AV valves closed.
 12. Verify open PV-2 and PV-4.
 13. Verify closed PV-1, PV-3, PV-5 and PV-6.
-

Section Complete Quality_____

G.20. Perform Final Closure of SV-13 and Condition Dewar Fill Cap Assembly

Once SV-13 has warmed sufficiently to try final closure perform the following steps.

Note:

The time required to warm up sufficiently may be a few hours.

G.20.1. Verify that the Fill Cap Assembly is still evacuated and record:

Date:_____ Time of day _____

PFCG pressure:_____

G.20.2. Retorque SV-13 to 60 ± 5 in-lbs.

Quality_____

G.20.3. Open FCV.

G.20.4. Open/Verify open AV-3.

G.20.5. Open AV-8 and evacuate to < 25 mtorr as measured at AG-2b.

G.20.6. Close AV-8.

G.20.7. Ensure EV-12 closed.

G.20.8. Open AV-1.

G.20.9. Open AV-9 until pressure reaches 1.5 psig as read on gauge AG-1 and then close AV-9.

G.20.10. Close FCV.

G.20.11. Close AV-1 and record:

Time of day:_____ / PFCG pressure:_____

G.20.12. Open AV-8 and evacuate to < 25 mtorr as measured at AG-2b.

G.20.13. Close AV-8.

G.20.14. Verify closure of SV-13 by observing the pressure in the Fill Cap Assembly (PFCG) until satisfied that no gas is leaking into the Dewar Fill line. Record:

Time of day _____, PFCG pressure _____ torr

G.20.15. After 30 minutes record:

Time of day _____, PFCG pressure _____ torr.

Note:

If PFCG drops by more than 0.5 torr in 30 minutes, repeat steps G.18.2 through G.18.14.

G.20.16. Open AV-1.

- G.20.17. Open AV-9 until pressure reaches 0 psig as read on gauge AG-1 and close AV-9.
- G.20.18. Close AV-1.
- G.20.19. Close AV-3.
- G.20.20. Turn off pump AP-1
- G.20.21. Remove pumping line from Fill Cap Assembly.
- G.20.22. Install KF-25 blank-off cap on valve FCV.

Section Complete Quality_____

G.21. Establish Final Configuration

G.21.1. (Option) Return Pumping of SMD to Gas Module Pump :

- o Main Tank is to be pumped by AP-1, perform this section
 - o Main Tank to continue being pumped by Pump Module or is not vented (SV-9 closed), skip this section
1. Verify closed all AV valves.
 2. Verify on/turn on AP-1.
 3. Open AV-8.
 4. When AG-2b < 50 mtorr, open AV-6.
 5. Close EV-4.
 6. Shut down pump module
 - a. Close EV-21.
 - b. Close PV-1.
 - c. Power down PP-1 and PP-2.
 - d. Close PV-3.

G.21.2. Record final liquid levels:

1. Main Tank level (LL-1D or LL-2D): _____ %
2. Guard Tank Level (LL-5D or LL-6D): _____ %

G.21.3. Record Main Tank pressure (EG-2): _____ torr.

G.21.4. Record Guard Tank pressure (GTV-G) _____ torr (relative to atm).

G.21.5. Turn off Guard Tank vent line heat exchanger (EH-2).

G.21.6. Verify final valve configuration:

1. Verify open EV-7a/b, EV-10, EV-13, EV-17.
2. Record position of EV-7a _____ % EV-7b _____ %.
3. Verify all other EV valves closed.
4. Verify AV-6 open.

| | | | | | | | | | | | |
|--|--|--|--|--|--|--|--|--|--|--|--|
| | | | | | | | | | | | |
| | | | | | | | | | | | |
| | | | | | | | | | | | |
| | | | | | | | | | | | |
| | | | | | | | | | | | |
| | | | | | | | | | | | |
| | | | | | | | | | | | |
| | | | | | | | | | | | |
| | | | | | | | | | | | |
| | | | | | | | | | | | |
| | | | | | | | | | | | |
| | | | | | | | | | | | |

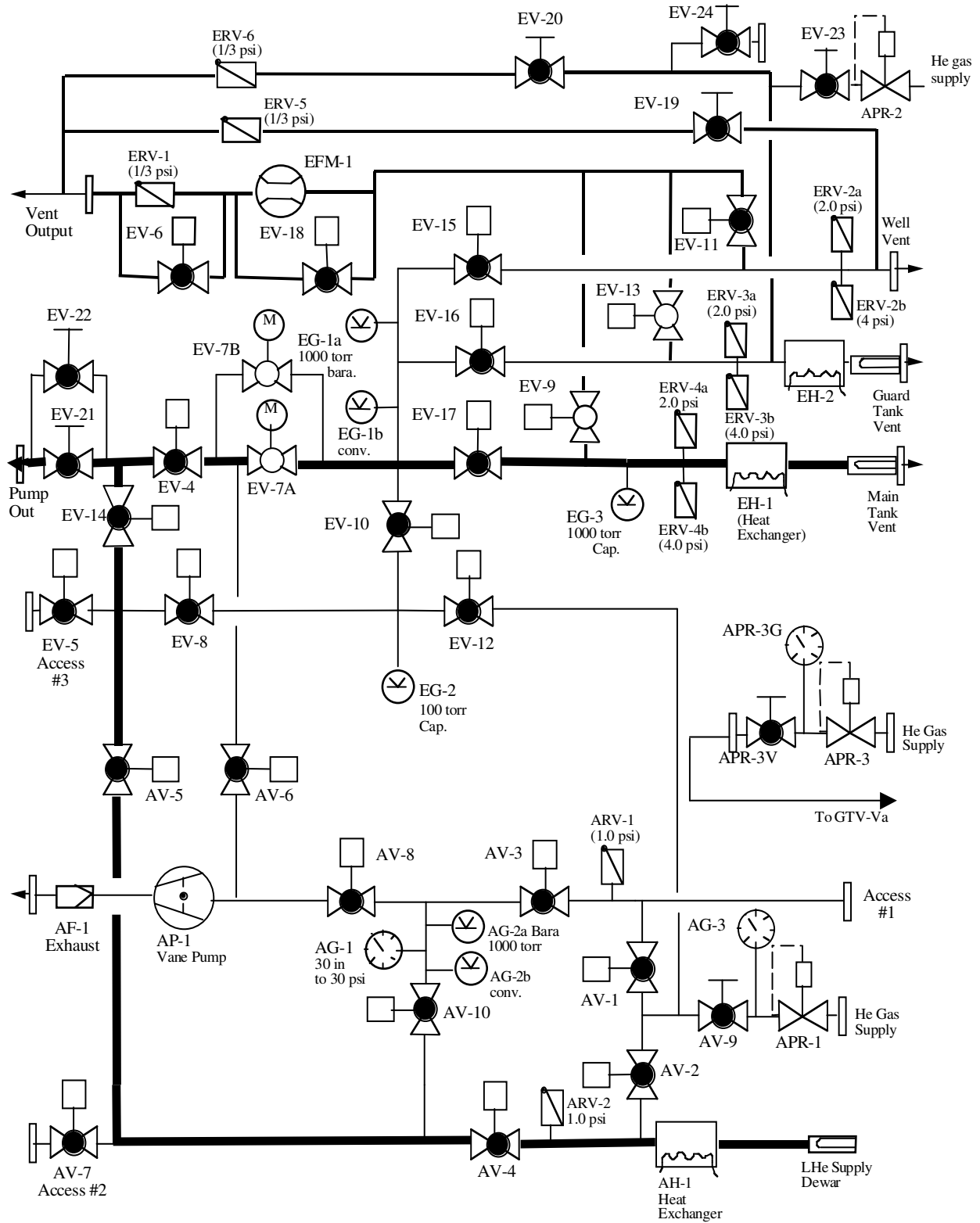

Figure 1. Schematic of Gas Module Plumbing.

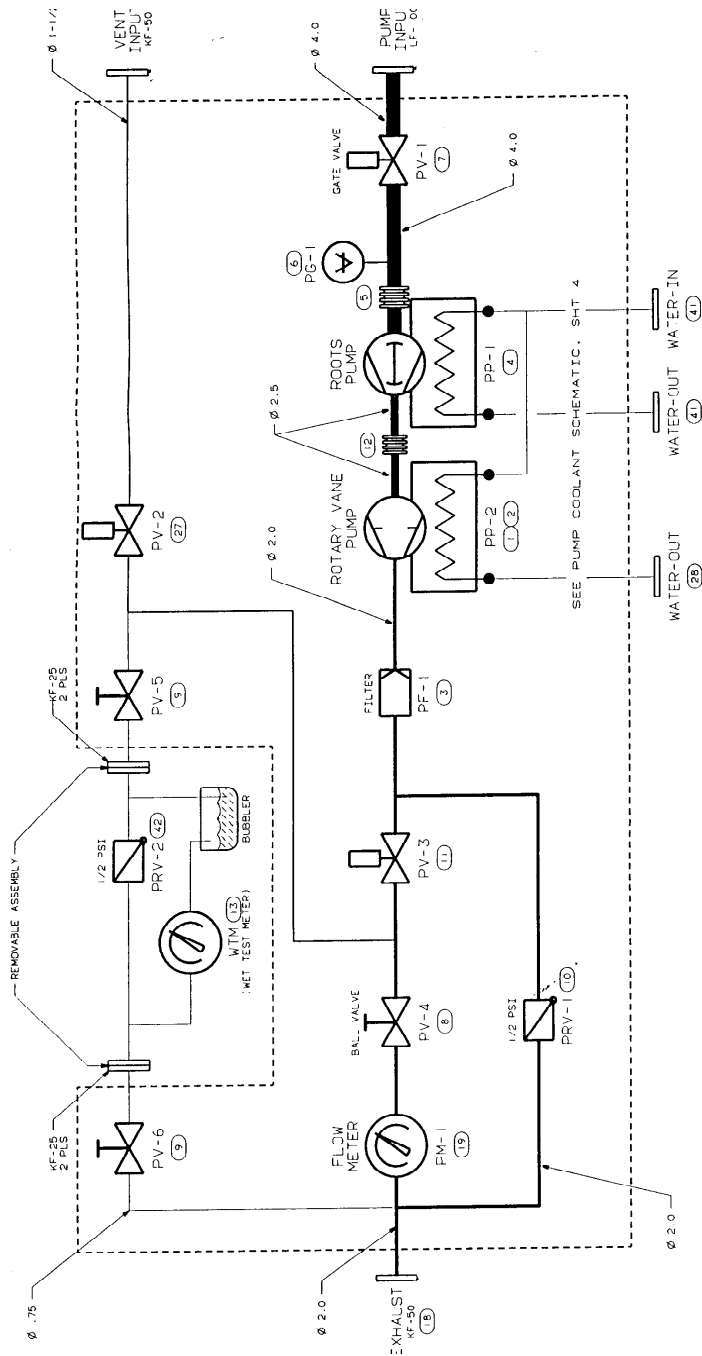

Figure 2. Schematic of Pump Module plumbing.

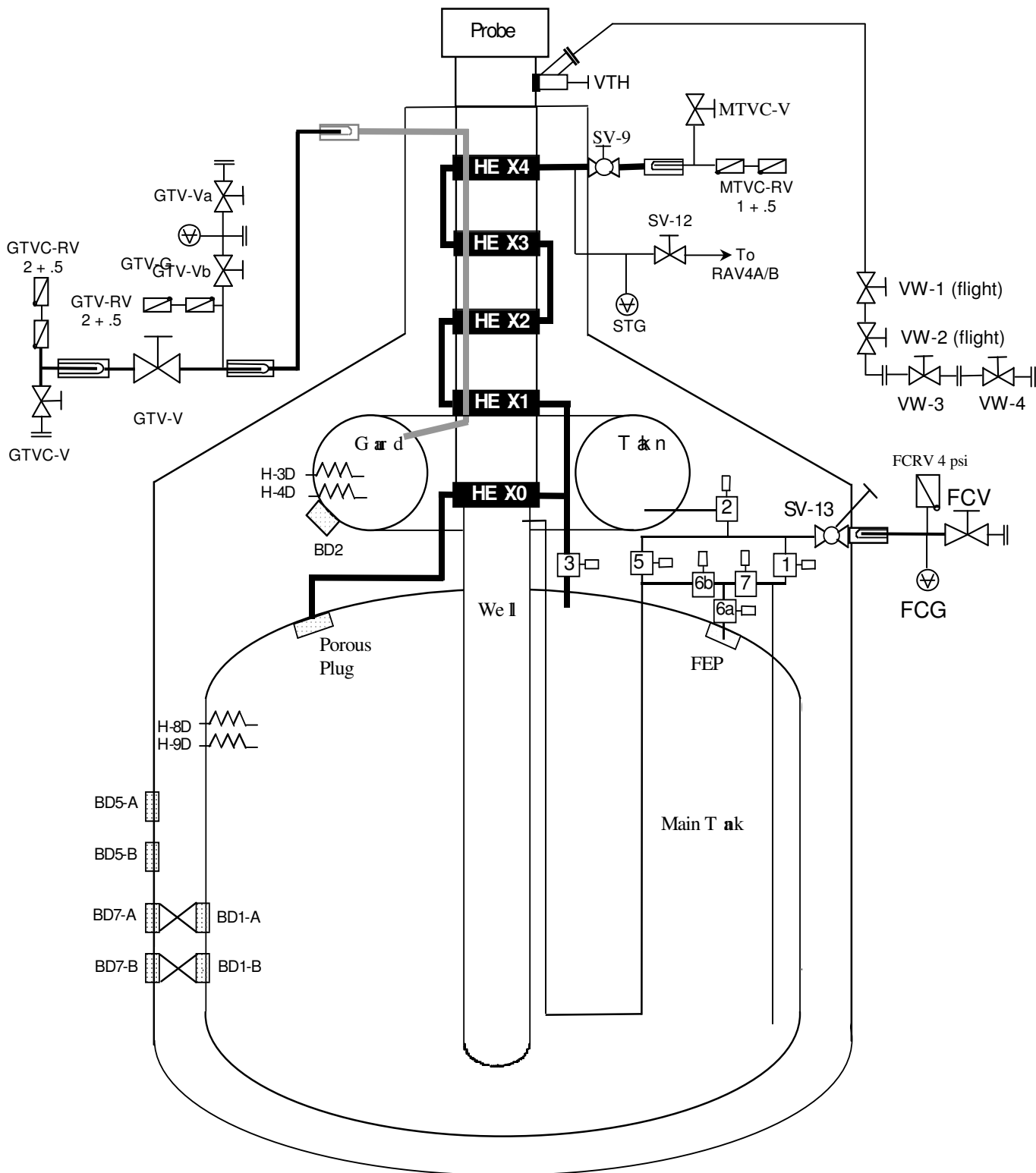

Figure 3 Schematic representation of SMD and GSE plumbing.

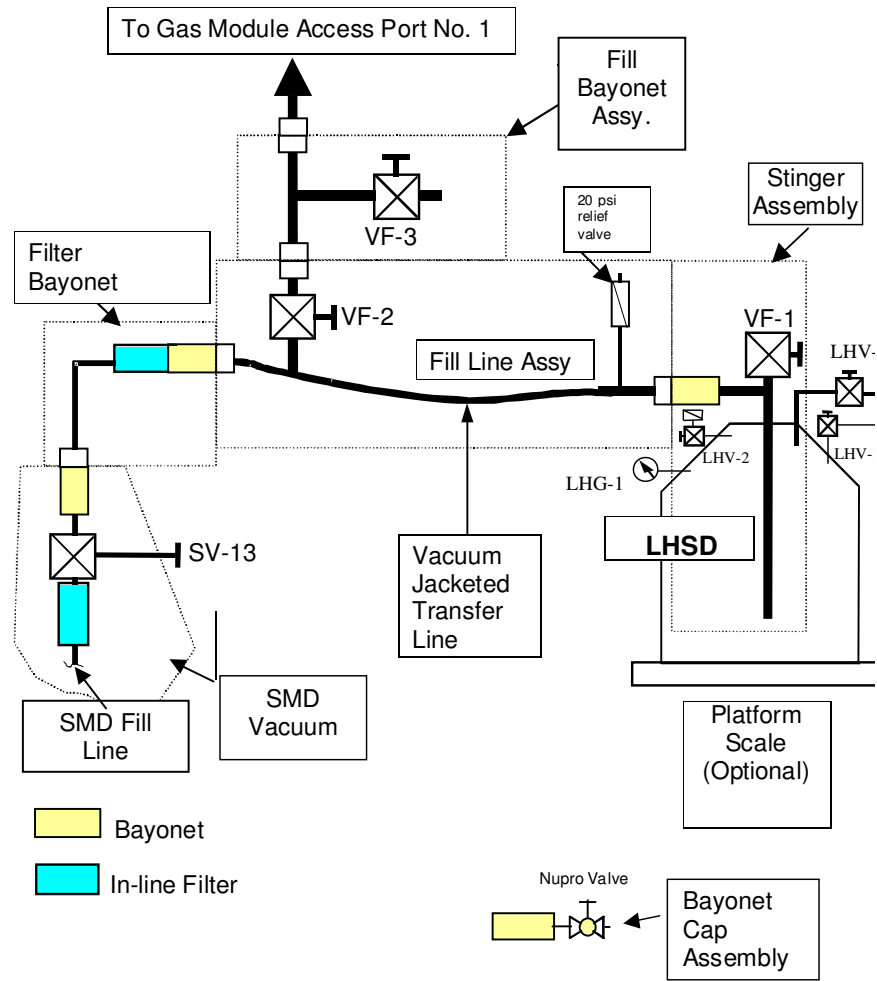

Figure 4 Schematic representation of LHSD and Transfer Line Plumbing

Appendix 1

| DATE | CHECKLIST ITEM | COMPLETE D | REMARKS |
|------|--|---------------|---------|
| | 1. Verify the test procedure being used is the latest revision. | | |
| | 2. Verify all critical items in the test are identified and discussed with the test team. | | |
| | 3. Verify all required materials and tools are available in the test area. | | |
| | 4. Verify all hazardous materials involved in the test are identified to the test team. | | |
| | 5. Verify all hazardous steps to be performed are identified to the test team. | | |
| | 6. Verify each team member is certified for the task being performed and knows their responsibilities.. | | |
| | 7. Confirm that each test team member clearly understands that he/she has the authority to stop the test if an item in the procedure is not clear. | | |
| | 8. Confirm that each test team member clearly understands that he/she must stop the test if there is any anomaly or suspected anomaly. | | |
| | 9. Notify management of all discrepancy reports or d-log items identified during procedure performance. In the event an incident or major discrepancy occurs during procedure performance management will be notified immediately. | | |
| | 10. Verify/perform an Engineering and Safety high-bay walk down. Ensure all discrepancies are corrected prior to start of operations. | | |
| | 11. Confirm that each test team member understands that there will be a post-test team meeting. | | |
| | Team Lead Signature: _____ | | |

I. **APPENDIX 2**

| DATE | CHECKLIST ITEM | COMPLETED | REMARKS |
|------|--|-----------|---------|
| | 1. Verify all steps in the procedure were successfully completed. | | |
| | 2. Verify all anomalies discovered during testing are properly documented. | | |
| | 3. Ensure management has been notified of all major or minor discrepancies. | | |
| | 4. Ensure that all steps that were not required to be performed are properly identified. | | |
| | 5. If applicable sign-off test completion. | | |
| | 6. Verify all RAV valve operations have been entered in log book | | |
| | 7. Verify the as-run copy of procedure has been filed in the appropriate binder | | |
| | Team Lead Signature: _____ | | |

J. **APPENDIX 3 – CONTINGENCY/EMERGENCY RESPONSES**

| Condition | Circumstance | Response |
|---|-------------------------|---|
| Power Failure | Anytime | Wait for power restoration, and resume procedure |
| Liquid nitrogen spill | Anytime | Clear area until all spilled liquid has evaporated |
| Temperature limits (CN 175 or 178) exceeded | Anytime | Close EV-17 (if open) and open EV-9. Crack open SV-9 to allow MT to vent. Adjust SV-9 as necessary to restore temperature(s) below alarm limits. Open EV-6 and EV-18 if higher flow rate is needed. |
| Burst disk rupture (MT/GT) | Anytime | Evacuate room |
| RAV-2 fails to operate | When requested to open | Wait until problem is resolved |
| | When requested to close | Close SV-13 and torque to 60 in-lbs. When ready to re-attempt closing of RAV-2, reopen SV-13. |
| Oxygen Monitor Alarm | Anytime | Evacuate room |