

GRAVITY PROBE B PROCEDURE FOR SCIENCE MISSION DEWAR

CONNECT GUARD TANK VENT LINES TO GAS MODULE

To be performed in Vandenberg Air Force Base building 1610

WARNING: THIS DOCUMENT CONTAINS HAZARDOUS OPERATIONS

P1008

June 29, 2002

Written by:

_____ Date _____
Ned Calder
Cryogenic Test

Approvals:

_____ Date _____
Dorrene Ross
Quality Assurance

_____ Date _____
Harv Moskowitz
LMMS Safety

_____ Date _____
Rob Brumley
Program Technical Manager

_____ Date _____
Mike Taber
Test Director

_____ Date _____

NASA/KSC Safety

REVISION RECORD

REVISION	ECO	PAGES	DATE

Table of Contents

A. SCOPE.....	2
B. SAFETY	2
B.1. Potential Hazards	2
B.2. Mitigation of Hazards	2
B.3. Mishap Notification	3
C. QUALITY ASSURANCE	3
C.1. QA Notification.....	3
C.2. Red-line Authority	3
C.3. Discrepancies	4
D. TEST PERSONNEL	4
D.1. Personnel Responsibilities.....	4
D.2. Personnel Qualifications	4
D.3. Required Personnel	4
E. REQUIREMENTS.....	5
E.1. Electrostatic Discharge Requirements	5
E.2. Lifting Operation Requirements	5
E.3. Hardware/Software Requirements.....	5
E.4. Instrument Pretest Requirements	6
E.5. Configuration Requirements	8
E.6. Optional Non-flight Configurations.....	8
F. REFERENCE DOCUMENTS.....	9
F.1. Drawings.....	9
F.2. Supporting documentation.....	9
F.3. Additional Procedures.....	9
G. OPERATIONS.....	10
G.1. Pre-Operations Verifications.....	10
G.2. Verify Purity of All Sources of Helium Gas.....	10
G.3. Verify Configuration Requirements.....	11
G.4. Record Initial Configuration and Conditions.....	11
G.5. Remove Guard Tank Vent Cap and Install Vent Line	13
G.6. Leak Check Guard Tank Vent Line.....	13
G.7. Establish Final Configuration	17
H. APPENDIX 1 PRE OPERATIONS CHECKLIST.....	27
I. APPENDIX 2 POST OPERATIONS CHECKLIST	28
J. APPENDIX 3– CONTINGENCY RESPONSES	29

List of Abbreviations and Acronyms

AG-x	Gauge x of Gas Module auxiliary section	MT	Main Tank
AMI	American Magnetics Inc.	MTVC	Main Tank Vent Cap
ATC	Advanced Technology Center	MTVC-G	Main Tank Vent Cap pressure gauge
Aux	Auxiliary	MTVC-RV	Main Tank Vent Cap relief valve
AV-x	Valve x of Gas Module auxiliary section	MTVC-V	Main Tank Vent Cap valve
Bot	Bottom	NBP	Normal boiling point
CN [xx]	Data acquisition channel number	ONR	Office of Naval Research
DAS	Data Acquisition System	PFCG	Fill Cap assembly pressure Gauge
EFM	Exhaust gas Flow Meter	PFM	Pump equipment Flow Meter
EG-x	Gauge x of Gas Module exhaust section	PG-x	Gauge x of Pump equipment
EM	Electrical Module	PM	Pump Module
ERV-x	Relief valve of Gas Module exhaust section	psi	pounds per square inch
EV-x	Valve number x of Gas Module exhaust section	psig	pounds per square inch gauge
FCV	Fill Cap Valve	PTD	Payload Test Director
FIST	Full Integrated System Test	PV-x	Valve x of the Pump equipment
GHe	Gaseous Helium	QA	Quality Assurance
GM	Gas Module	RAV-x	Remote Actuated Valve-x
GP-B	Gravity Probe-B	RGA	Residual Gas Analyzer
GSE	Ground Support Equipment	SMD	Science Mission Dewar
GT	Guard Tank	STV	SMD Thruster vent Valve
GTVc	Guard Tank Vent Cap	SU	Stanford University
GTVc-G	Guard Tank Vent Cap pressure gauge	SV-x	SMD Valve number x
GTVc-RV	Guard Tank Vent Cap relief valve	TG-x	Gauge x of Utility Turbo System
GTVc-V	Guard Tank Vent Cap valve	TV-x	Valve x of Utility Turbo System
GTV-G	Guard Tank vent pressure gauge	UTS	Utility Turbo System
GTV-RV	Guard Tank vent relief valve	Vac	Vacuum
GTV-V	Guard Tank vent valve	VCP-x	Vent cap pressure gauge
HX-x	Vent line heat exchanger in Gas Module	VCRV-x	Vent cap relief valve
KFxx	Quick connect o-ring vacuum flange (xx mm diameter)	VCV-x	Vent cap valve
LHe	Liquid Helium	VDC	Volts Direct Current
LHSD	Liquid Helium Supply Dewar	VF-x	Liquid helium Fill line valve
Liq	Liquid	VG-x	Gauge x of Vacuum Module
LL	Liquid level	VM	Vacuum Module
LLS	Liquid level sensor	VV-x	Valve x of Vacuum Module
LMMS	Lockheed Martin Missiles and Space	VW-x	Valve x of Dewar Adapter
LMSC	Lockheed Missiles and Space Co.		

LIST OF SPECIFIC HEADING DEFINITIONS

Each type of alert message will precede the procedural step to which it applies

1. NOTE: Used to indicate an operating procedure of such importance that it must be emphasized
2. CAUTION: Used to identify hazards to equipment
3. WARNING: Used to identify hazards to personnel

A. SCOPE

This procedure provides the necessary steps to remove the Guard Tank Vent Cap and connect the Guard Tank Vent Line/s to the Gas Module. The steps include:

- Close off vent line at Guard Tank Vent Valve (GTV-V)
- Remove Vent Cap
- Install and leak check Guard Tank vent line

The procedure is applicable when the Guard Tank contains liquid, as well as, when it is depleted. The Main Tank vent line may be connected or disconnected from the Gas Module. The Main Tank liquid may be at normal boiling point or subatmospheric.

The hazardous operation contained in this procedure is the handling of cryogenic nitrogen to service the detector.

B. SAFETY**B.1. Potential Hazards**

Personal injury and hardware damage can result during normal positioning, assembly and disassembly of hardware.

Liquid helium used in the SMD represents a hazardous material for the personnel involved in the operations. Cryogenic burns can be caused by contact with the cold liquid or gas, high pressures can result if boiling liquid or cold gas is confined without a vent path, and asphyxiation can result if the vent gas is allowed to accumulate.

The SMD Safety Compliance Assessment, document GPB-100153C, and the Missile System Prelaunch Safety Package LM/P479945 discuss the safety design, operating requirements and the hazard analysis of the SMD.

B.2. Mitigation of Hazards**B.2.1. Lifting hazards**

There are no lifting operations in this procedure

B.2.2. Cryogenic Hazards

In addition, the GP-B cryogenic team provides an oxygen deficiency monitor that alarms when the oxygen level is reduced to 19.5%. Additional temperature and pressure alarms, provided by the DAS, warn of potential over-pressure conditions. Emergency vent line deflectors are installed over the four burst disks to direct any flow to an outside area.

Only authorized and trained personnel are allowed in VAFB facilities without escort. All personnel working on platforms at a height 30 inches or more off the floor are required to have an approved air tank (emergency breathing apparatus) within easy reach. Note that tank need not be kept available when working from ladder. In the unlikely event of a large LHe spill all employees have been instructed to

evacuate the room and contact NASA and VAFB safety. The fall back area will be building 1605.

The following additional requirements apply to all personnel involved directly in cryogenic operations. Gloves that are impervious to liquid helium and liquid nitrogen are to be worn whenever the possibility of splashing or impingement of high-velocity cryogens exists or when handling equipment that has been cooled to cryogenic temperatures. Protective clothing, non-absorbent shoes and full-face shield with goggles/glasses are to be worn whenever the possibility of splashing cryogens exists.

B.2.3. Other Hazards

All tools or other items used with the potential to damage the SMD or Probe shall be tethered.

B.3. **Mishap Notification**

B.3.1. Injury

In the event of fire or illness/injury requiring emergency medical treatment **DIAL 911**

B.3.2. Hardware Mishap

In case of an accident, incident, or mishap, notification is to proceed per the procedures outlined in Lockheed Martin Engineering Memorandum EM SYS229 and Stanford University GP-B P0879. Additionally, VAFB NASA Safety and 30th Space Wing Safety will be notified as required.

B.3.3. Contingency Response

Responses to contingencies/emergencies (e.g., power failure) are listed in Appendix 3.

C. **QUALITY ASSURANCE**

C.1. **QA Notification**

The NASA program and NASA safety representative and SU QA shall be notified 24 hours prior to the start of this procedure. Upon completion of this procedure, the QE Manager will certify his/her concurrence that the effort was performed and accomplished in accordance with the prescribed instructions by signing and dating in the designated place(s) in this document.

C.2. **Red-line Authority**

Authority to red-line (make minor changes during execution) this procedure is given solely to the PTD or his designate and shall be approved by the QA Representative. Additionally, approval by the Payload Technical Manager shall be required, if in the judgement of the PTD or QA Representative, experiment functionality may be affected. Within hazardous portions of this procedure, all steps shall be worked in sequence. Out-of-sequence work or redlines will be approved by NASA Safety prior to their performance.

C.3. Discrepancies

A Quality Assurance Representative designated by D. Ross shall review any discrepancy noted during this procedure, and approve its disposition. Discrepancies will be recorded in a D-log or a DR per Quality Plan P0108. Any time a procedure calls for verification of a specific configuration and that configuration is not the current configuration, it represents a discrepancy of one of three types. These types are to be dealt with as described below.

1. If the discrepancy has minimal effect on procedure functionality (such as the state of a valve that is irrelevant to performance of the procedure) it shall be documented in the procedure, together with the resolution. Redlines to procedures are included in this category.
2. If the discrepancy is minor and affects procedure functionality but not flight hardware fit or function, it shall be recorded in the D-log. Resolution shall be in consultation with the PTD and approved by the QA representative.
3. All critical and major discrepancies, those that effect flight hardware fit or functions, shall be documented in a D-log and also in a Discrepancy Report, per P0108.

D. TEST PERSONNEL**D.1. Personnel Responsibilities**

The performance of this procedure requires a minimum complement of personnel as determined by the Test Director. The person performing the operations (Test Director or Test Engineer) is to sign the "Completed by" sign-off. Any other qualified person or QA person who can attest to the successful performance of this procedure may sign the "Witnessed by" sign-off. **The Test Director will perform Pre-Test and Post-Test Briefings in accordance with P0875 "GP-B Maintenance and Testing at all Facilities." Checklists will be used as directed by P0875**

D.2. Personnel Qualifications

The Test Director must have a detailed understanding of all procedures and facility operations and experience in all of the SMD operations. Test Engineers must have SMD Cryogenic operations experience and an understanding of the operations and procedures used for the cryogenic servicing/maintenance of the Dewar.

D.3. Required Personnel

The following personnel are essential to the accomplishment of this procedure:

FUNCTIONAL TITLE	NUMBER	AFFILIATION
Test Director/Test Engineer	1	Stanford
GP-B Quality Assurance	1	Stanford
NASA Safety Rep	1	SFAO or ANALEX

E. REQUIREMENTS

E.1. Electrostatic Discharge Requirements

When working on the space vehicle, proper ESD protection is required. The wrist-strap will be checked using an appropriate calibrated checker prior to use..

E.2. Lifting Operation Requirements

There are no lifting operations in this procedure

E.3. Hardware/Software Requirements

E.3.1. Commercial Test Equipment

No commercial test equipment is required for this operation.

E.3.2. Ground Support Equipment

The Ground Support Equipment includes the Gas Module, the Electrical Module. The Gas Module provides the capability to configure vent paths, read pressures and flow rates, and pump and backfill vent lines. The Pump Module provides greater pumping capacity than the Gas Module, together with additional flow metering capabilities. The vent output of the Gas Module flows through the Pump Module. The Electrical Module contains the instruments listed in Table 1, and provides remote control of valves in the Gas Module, Pump Module, and SMD.

E.3.3. Computers and Software:

The Data Acquisition System (DAS) and data acquisition software are required for this procedure. The DAS reads and displays pressures, temperatures, and flow rates and monitors critical parameters. No additional computers or software are required.

E.3.4. Additional Test Equipment

<i>Description</i>
Utility Turbo System (UTS, see Figure 3)
Helium leak detector
Helium leak detector calibrated leak; Cal. Leak due date: _____ S/N #: _____

E.3.5. Additional Hardware

1. Guard Tank Vent Line
2. 4 liter thermos

E.3.6. Tools

No additional tools are required.

E.3.7. Personnel Protective Equipment

1. Cryogenic safety gloves and apron
2. Face shield
3. Goggles/glasses
4. Non-absorbent shoes
5. Rubber gloves (if ethanol is to be used)

E.3.8. Expendables

<p>WARNING</p> <p>Ethanol is highly flammable and vapor/air mixtures are Explosive.</p> <p>Exposure hazards include: Inhalation (headache/fatigue),</p> <p>skin (dryness, eyes (redness/pain/burning))</p>
--

<i>Description</i>	<i>Quantity</i>	<i>Mfr./Part No.</i>
Ethanol	AR	N/A
99.999% pure gaseous helium	AR	N/A
Vacuum Grease	AR	Apeizon N or Dow Corning High Vacuum Grease

E.4. Instrument Pretest Requirements

The GSE instruments required to perform this procedure are listed in Table 1, together with their serial numbers, where available. Instruments that are required to have current calibrations are indicated in the Cal-Required column. Instruments that do not require calibration are those not used to verify performance requirements and are not connected to flight instrumentation. The status column is to be filled in with the due date of the instrument calibration sticker and verified to be in calibration by QE or QE designee.

Table 1. Required Instrumentation and Calibration Status

<i>No.</i>	<i>Location</i>	<i>Description</i>	<i>Name</i>	<i>Serial No.</i>	<i>Cal Required</i>	<i>Status Cal due date</i>
1	DAS	Power Supply, H-P 6627A	-	3452A01975	Yes	
2	DAS	Power Supply, H-P 6627A	-	3452A01956	Yes	
3	DAS	Data Acquisition/Control Unit H-P 3497A	-	2936A245539	No	-
4	DAS	Digital Multimeter H-P 3458A	-	2823A15047	Yes	
5	EM	Vacuum Gauge Controller Granville-Phillips Model 316	EG-1a, -1b	2827	No	-
6	EM	Vacuum Gauge Controller Granville-Phillips Model 316	AG-2a, -2b	2826	No	-
7	EM	Vacuum Gauge Controller Granville-Phillips Model 316	EG-3	2828	No	-
8	EM	MKS PDR-C-2C	EG-2, FCG	92022108A	No	-

No.	Location	Description	Name	Serial No.	Cal Required	Status Cal due date
9	EM	Flow meter – Matheson 8170	EFM-1	96186	No	-
10	EM	Flow meter totalizer Matheson 8124	EFM-1	96174	No	-
11	EM	Liquid Helium Level Controller American Magnetics, Inc. 136	LLS Main Tank	96-409-11	No	-
12	EM	Liquid Helium Level Controller American Magnetics, Inc. 136	LLS Guard Tank	96-409-10	No	-
13	EM	Liquid Helium Level Controller American Magnetics, Inc. 136	LLS Well	96-409-9	No	-
14	EM	Liquid Helium Level Controller American Magnetics, Inc. 136	LLS Axial Lock	96-409-12	No	-
15	EM	Pressure Controller – MKS 152F-92	EV-7a, -7b	96203410A	No	-
16	EM	Power Supply HP 6038A	H08D Tank Heater	96023407A	Yes	
17	EM	Power Supply HP 6038A	H09D Tank Heater	3511A-13332	Yes	
18	EM	Power Supply HP 6038A	RAV Power Supply	3329A-12486	Yes	
19	EM	Vac Ion Pump power supply Varian 929-0910, Minivac	SIP	5004N	No	-
20	EM	Flow meter totalizer Veeder-Root	PFM-1	576013-716	No	-
21	GM	Pressure Gauge, Heise	AG-1	CC-122077	No	-
22	GM	Pressure Gauge, Marshall Town	AG-3	N/A	No	-
23	GM	Main Tank Heat Exchanger: a) Thermocouple, b) Current meter, c) Temperature set point controller	-	C-19950	No	-
24	GM	Guard Tank Heat Exchanger: a) Thermocouple, b) Current meter, c) Temperature set point controller	-	C-09920	No	-
25	VM	Vacuum Gauge readout, Granville-Phillips 316	VG-3 VG-4	2878	No	-
26	VM	Vacuum Gauge readout, Granville-Phillips 360	VG-1, VG-2 VG-5	96021521	No	-

E.5. Configuration Requirements**E.5.1. Main Tank**

Liquid in the Main Tank may be at normal boiling point (NBP) or subatmospheric. When subatmospheric, the initial configuration of the Gas Module may be such that the bath is being actively pumped or is set up in a non-vented mode.

E.5.2. Guard Tank

The Guard-Tank may contain liquid, or be depleted. When the Guard Tank is depleted, its pressure must be independently regulated from a source of 99.999% pure helium gas and its pressure must be continuously monitored and maintained at a positive value relative to that of the atmosphere. Monitoring is accomplished by placing the relative pressure (GTV-G), as read at the Guard Tank Vent Valve Assembly, on the DAS alarm list.

E.5.3. Well

The Well is evacuated.

E.5.4. SMD Vacuum Shell

The Vacuum Shell pressure must be less than 5×10^{-5} torr.

E.5.5. Alarm System

1. The DAS alarm system must be enabled and contain the following alarm set-points:
 - a. Top of lead bag temperature set (CN 28 and CN 29) at $T \leq 6.0$ K.
 - b. Relative Guard Tank Pressure (CN 46) set at $\Delta P \geq 0.3$ torr.

E.5.6. GSE and Non-flight Hardware

1. GSE cabling must be connected between the SMD and the Electrical Module (P/N 5833812) and between the SMD and the Data Acquisition System (P/N 5833811).
2. Guard Tank Long and Short Vent Lines

E.6. Optional Non-flight Configurations

The following modifications or non-flight arrangement of the basic SMD configuration may also be in place. They are incidental to the performance of this procedure and not required.

1. The SMD/Space Vehicle is installed in the Tilt dolly.
2. The ion-pump magnet is installed.
3. The Main Tank Vent Line may be connected to the Gas Module, or it may be disconnected either at the Bayonet at the end of the short line or the Bayonet at SV-9.

4. The Vacuum shell pump out port at SV-14 may be connected to the Vacuum Module (P/N 5833816) via a 2-in valve operator and pumping line, with the valve in the closed position or in the open position with the Vacuum Module actively pumping the vacuum shell.
5. The Fill Cap Assembly is installed at SV-13.

F. REFERENCE DOCUMENTS

F.1. Drawings

<i>Drawing No.</i>	<i>Title</i>
LMMS-5833394	Instrumentation Installation

F.2. Supporting documentation

<i>Document No.</i>	<i>Title</i>
LMMC-5835031	GP-B Magnetic Control Plan
GPB-100153C	SMD Safety Compliance Assessment
LM/P479945	Missile System Prelaunch Safety Package
SU/GP-B P0141	FIST Emergency Procedures
LMSC-P088357	Science Mission Dewar Critical Design Review
SU/GP-B P0108	Quality Plan
LMMS GPB-100333	Science Mission Dewar Failure Effects and Causes Analysis
SU/GP-B P059	GP-B Contamination Control Plan
EWR 127-1 :	Eastern and Western Range Safety Requirements
EM SYS229	Accident/Mishap/Incident Notification Process
KHB 1710.2 rev E	Kennedy Space Center Safety Practices Handbook

F.3. Additional Procedures

<i>Document No.</i>	<i>Title</i>
SU/GP-B P0879	Accident/Incident/Mishap Notification Process
SU/GP-B P1015	Connect Vacuum Module to SMD
SU/GP-B P0875	GP-B Maintenance and Testing at all Facilities

Operation Number: _____

Date Initiated: _____

Time Initiated: _____

G. OPERATIONS

G.1. Pre-Operations Verifications

- o Verify SU QA notified.
Record: Individual notified _____,
Date/time ____/____.
- o Verify NASA program representative notified.
Record: Individual notified _____,
- o Verify NASA safety representative notified.
Record: Individual notified _____,
- o Record calibration due dates in Table 1 (Sections. E.3.4, E.4)
- o Persons actually performing this procedure should initial their names in Sec D.3 and the name of the Test Director should be circled.
- o Verify completion of the Pre-Operations Checklist (Appendix 1).
- o Verify Guard Tank Vent Line Disconnected-if Guard Tank Vent Line is connected terminate procedure.
- o Verify proper operation of the GP-B Cryogenic Group oxygen monitor
- o Verify availability and functioning of emergency shower.

QA Witness: _____

G.2. Verify Purity of All Sources of Helium Gas

G.2.1. Record serial number of helium bottle/s.

- 1. _____ 2. _____ 3. _____
- 4. _____ 5. _____ 6. _____

Verify helium bottle/s have been tested for purity and record Op. Number.

Op. Number: _____

QA Witness: _____

G.3. **Verify Configuration Requirements**

G.3.1. Ensure DAS alarm system enabled and record set points.

1. **Top of lead bag temperature** – ensure CN [28] and CN [29] on DAS alarm list with alarm limit at $T \leq 6.0$ K. Record set point. _____ K

2. **Relative Guard Tank Pressure** – ensure CN [46] on DAS alarm list with alarm limit at $\Delta P \geq 0.3$ torr. Record set point. _____ torr

G.3.2. Ensure liquid-level alarms set, as appropriate, and record set points.

1. **Main Tank** – ensure liquid-level alarm set $\geq 20\%$. Record set point. _____ %

2. **Guard Tank** – ensure liquid level alarm set $\geq 10\%$ (if liquid in GT). Record set point. _____ %

G.3.3. Ensure GSE cabling connected as appropriate between the SMD and the Electrical Module (P/N 5833812) and between the SMD and the Data Acquisition System (P/N 5833811).

Section Complete QA Witness: _____

G.4. **Record Initial Configuration and Conditions**

G.4.1. Record initial liquid helium levels as appropriate.

1. Main Tank (LL-1D or LL-2D) _____ %

2. Guard Tank (LL-5D or LL-6D) _____ %

G.4.2. Record initial pressures, as appropriate.

1. Main Tank – Subatmospheric (EG-2/STG): _____ torr.

2. Main Tank – NBP (EG-3/STG): _____ torr.

3. Guard Tank – (GTV-G) _____ torr relative to 1 atm.

G.4.3. Record condition of Main Tank (**one** of the following) and ensure corresponding valve configurations.

<ul style="list-style-type: none">o Main Tank not connected to Gas Module<ol style="list-style-type: none">1. Ensure all EV valves closed.2. Ensure all AV valves closed.<ol style="list-style-type: none">a.
<ul style="list-style-type: none">o Main Tank connected to Gas Module – liquid at NBP.<ol style="list-style-type: none">1. Ensure EV-9 open.2. Ensure all other EV valves closed.3. Ensure all AV valves closed.
<ul style="list-style-type: none">o Main Tank connected to Gas Module – liquid sub-atmospheric and pumped by Pump Module (PP-1/PP-2).<ol style="list-style-type: none">1. Ensure EV-10 and EV-17 open.2. Ensure EV-4, EV-7a/b, and EV-21 open.3. Ensure all other EV valves closed.4. Ensure all AV valves closed.5. Ensure PV-1, PV-3, and PV-4 (or PV-1, PV-3, PV-5 and PV-6) open.6. Ensure PP-1 and PP-2 on.
<ul style="list-style-type: none">o Main Tank connected to Gas Module – liquid sub-atmospheric and pumped by Gas Module (AP-1).<ol style="list-style-type: none">1. Ensure EV-10 and EV-17 open.2. Ensure EV-7a/b open .3. Ensure all other EV valves closed.4. Ensure AP-1 on5. Ensure AV-6 open.6. Ensure all other AV valves closed

- G.4.4. Record condition of Guard Tank
- o Guard Tank contains liquid.
 - o Guard Tank depleted and pressure independently regulated at GTV-Va-

QA Witness: _____

G.5. Remove Guard Tank Vent Cap and Install Vent Line

- G.5.1. Close/verify closed GTVC-V.
- G.5.2. Close GTV-V
- G.5.3. Enter comment in DAS "Closed Guard Tank vent valve GTV-V."
- G.5.4. Remove Guard Tank Vent Cap Assembly
- G.5.5. Remove o-ring from bayonet receptacle and inspect for defects or damage. Replace if any found and record results in o-ring log.
- G.5.6. Clean and grease o-ring with Apiezon N high vacuum grease before replacing.
- G.5.7. Install Guard Tank Long Vent Line at GTV-V.
- G.5.8. Ensure black marks on nut line up with black marks on threads.
- G.5.9. Connect Guard Tank Vent line at Gas Module (at inlet to Guard Tank heat exchanger).

Section Complete QA Witness: _____

WARNING

The following operation contains hazardous operations. When filling the nitrogen trap in the leak detector, wear cryogenic safety apron, gloves, face shield with goggles/glasses, and non-absorbent shoes. Failure to comply may result in personal injury.

G.6. Leak Check Guard Tank Vent Line

- G.6.1. Request NASA safety to make PA announcement that a hazardous task is about to begin
- G.6.2. Ensure area operation light is turned to Amber
- G.6.3. Establish a 6 foot controlled area
- G.6.4. Ensure all non-essential personnel are clear of the controlled area.
- G.6.5. Turn on and verify calibration of leak detector. Record
1. calibrated leak value _____ sccs

2. measured leak value _____ sccs

NOTE

Hazardous operations are now complete.

- G.6.6. Request NASA Safety make PA announcement that the hazardous operation is complete.
- G.6.7. Ensure area operation light is returned to Green
- G.6.8. Disband controlled area
- G.6.9. Connect leak detector to the UTS at access port (LD).
- G.6.10. Ensure EV-5 closed
- G.6.11. Install UTS/Leak detector to Access port #3 of Gas Module and start the UTS (Figure 3) pumping up to closed EV-5, as follows:
 1. Place valve interlock switch in "over-ride" position.
 2. Turn on vane pump and converter (Note: converter switch provides power to turbopump controller and pirani and cold-cathode vacuum-gauge display.
 3. Push the red "reset" button to activate the interlock over-ride circuit. (the yellow-orange indicator light will come on).
 4. Turn "foreline" switch on, to open TV-2, and verify that the switch is illuminated.
 5. Push the "Sensor" button on the vacuum gauge display to read the foreline pressure (TG-4). This is the pirani gauge. The "Pir" annunciator will appear in upper left corner of the display).
 6. Slowly open TV-4.
 7. When foreline pressure (TG-4) < 1 torr, push "Start" button on turbo controller.
 8. When the "Normalbetrieb" light illuminates on turbo controller, indicating turbopump is up to speed, close TV-4 and open gate valve TV-1.
 9. Switch the valve interlock switch to the "protected" position.
 10. Push the "Sensor" button on the vacuum gauge readout so that the "Hi-Vac" annunciator shows, and push the "Emis" button to turn on the cold cathode gauge (TG-1).
 11. Record the pumping line pressure (TG-1) _____ torr.

CAUTION:

If the Main Tank is connected to the Gas Module and being pumped, the next step will stop the pumping and put the Main Tank in a non-vented mode. During the period of Main Tank vent closure the temperatures at the top of the lead bag are to be continuously monitored. Failure to comply may result in equipment damage.

G.6.12. Close/verify closed AV-6, EV-10, EV-17, and EV-21/22.

G.6.13. Open/verify open EV-4, EV-14, and EV-16.

G.6.14. Record settings of EV-7a _____ and EV-7b _____ and open fully.

G.6.15. Evacuate Guard Tank vent plumbing with Gas Module

1. Ensure AP-1 on.
2. Open AV-6 and AV-8.
3. Once pressure is < 25 mtorr as measured at AG-2b, close AV-6 and AV-8.

G.6.16. Bake out Gas Module

1. Open EV-5, now pumping up to closed GTV-V with UTS

Record TG-1: _____ torr

Record Time: _____

2. Turn on Guard Tank heat exchanger and set to 50C

3. Bake out heat exchanger until TG-1 < 5×10^{-6} torr

Record TG-1: _____ torr

Record Time: _____

4. Turn off Guard Tank heat exchanger

5. When TG-1 pressure stabilizes proceed to section G.6.10

Record TG-1: _____ torr

Record Time: _____

G.6.17. Leak check all plumbing and connections

1. Verify that leak detector is operational and pumping up to closed valve TV-3.
2. Leak check all plumbing and connections between leak detector and TV-3
3. Slowly open TV-3 and close the foreline valve (TV-2)
4. Pump until background level is on the 10^{-5} scc/s range.

G.6.18. Bag seals of vent line, purge bags with Ghe for 2 minutes and record:

1. O-ring location: _____

Time (min)	0	1/2	1	1 1/2	2
LD (ssc/s)					

2. Pass/Fail: _____ (Pass= **no** increase from initial background)

QA Witness: _____

3. O-ring location: _____

Time (min)	0	1/2	1	1 1/2	2
LD (ssc/s)					

4. Pass/Fail: _____ (Pass= **no** increase from initial background)

QA Witness: _____

G.6.19. Close EV-4, EV-5, and EV-14. Record Date/Time _____

G.6.20. Remove UTS/leak detector (if not going to use for more operations), as follows:

1. Close valve TV-3 and open foreline Valve (TV-2)
2. While monitoring the pressure on the cold cathode gauge (TG-1), vent and disconnect the leak detector
3. Close UTS gate valve (TV-1).
4. Turn turbo pump off.
5. Close foreline valve (TV-2) and turn off vane pump.
6. Install Ghe to UTS valve TV-5 upstream of gate valve and backfill to 760 torr, as read at TG-3.
7. Disconnect UTS from access port 3 at EV-5..

G.6.21. Backfill Gas Module to one atmosphere.

1. Open EV-10 and EV-12.
2. Open AV-9 and pressurize to 760 torr as read at gauge EG-1a and close AV-9.
3. Close EV-10, EV-12, and EV-16.

Section Complete QA Witness: _____

G.7. Establish Final Configuration

G.7.1. Record the following:

1. Date/time of day: _____ / _____
2. Main Tank Temp (T-9D): _____ K
3. Guard Tank Temp (T-15D) _____ K

Guard Tank pressure GTV-G _____ torr (relative to atm.)

G.7.2. Place Gas Module valves in initial configuration:

Note:

Before reestablishing Guard Tank venting, place the Gas Module valves in the same states they were in to start with (i.e., the states established in Paragraph G.3.3. Those states are repeated below.

-
- o Main Tank not connected to Gas Module.
 1. Ensure all other EV valves closed.
 2. Ensure all AV valves closed.
-
- o Main Tank connected to Gas Module – liquid at NBP.
 1. Ensure EV-9 open.
 2. Ensure all other EV valves closed.
 3. Ensure all AV valves closed.
-
- o Main Tank connected to Gas Module – liquid sub-atmospheric and pumped by Pump Module (PP-1/PP-2).
 1. Slowly release pressure in Guard Tank thru GTVVA until CN 46 drops to 120 torr
 2. Ensure EV-10 and EV-17 open.
 3. Ensure EV-4, EV-7a/7b, and EV-21 open.
 4. Ensure all other EV valves closed.
 5. Ensure all AV valves closed.
 6. Ensure PP-1 and PP-2 on.
 7. Ensure PV-1, PV-3, and PV-4 (or PV-1, PV-3, PV-5 and PV-6) open..
-

-
- o Main Tank connected to Gas Module – liquid sub-atmospheric and pumped by Gas Module (AP-1).
 1. Ensure EV-10 and EV-17 open.
 2. Ensure EV-7a/7b open .
 3. Ensure all other EV valves closed.
 4. Ensure AP-1 on
 5. Ensure AV-6 open.
 6. Ensure all other AV valves closed.
-

G.7.3. Establish one of the following Guard Tank vent configurations:

- o Guard Tank contains liquid – establish venting (Because the GT may be at much higher pressure than the MT, venting is established through EV-20.)
 1. Close/verify closed EV-13, EV-23, and GTV-Va.
 2. Open EV-20
 3. Open GTV-V
 4. Enter comment into DAS “GT venting through EV-20.”
 5. **Only** if Main Tank **not** subatmospheric, open EV-16.
-
- o Guard Tank depleted – pressure must be independently regulated.
 1. Ensure EV-13 and EV-20 closed.
 2. Close/verify closed GTV-Va
 3. Open GTV-V.
 4. Verify certified helium supply attached to APR-2.
 5. Ensure He supply regulator to 3-4 psid.
 6. While purging from both directions open GTV-Va and attach pressurization line.
 7. **Only** if Main Tank **not** subatmospheric, open EV-16.
-

- G.7.4. Ensure DAS alarm enabled and record set points if changed
 - o Thermal conditions substantially unchanged, alarm set point for the lead bag is unchanged
 - o Thermal conditions substantially changed, temperature alarm points reset as follows:
 - a. Top of Lead Bag set point _____ K (≤ 6.0 K)
[CN 28 and CN 29]

- G.7.5. Ensure liquid level sensor alarms enabled, as appropriate, and record set points if changed.
 - 1. Main Tank Level Set Point _____%
 - 2. Guard Tank Level Set Point _____%

- G.7.6. Ensure Guard Tank pressure on DAS alarm list and set to alarm ≥ 0.3 torr differential.

- G.7.7. Once conditions have stabilized, record the following:
 - 1. Date/time of day: _____ / _____
 - 2. Main Tank Temp (T-9D) CN [09] _____ K
 - 3. Guard Tank Temp (T-15D) CN [24] _____ K
 - 4. Guard Tank pressure (GTV-G) _____ torr relative to atm.
 - 5. Main Tank pressure
 - a. If connected to GM (EG-2 or EG-3) _____ torr
 - b. If disconnected from GM(STG) _____ torr relative to atm.

- G.7.8. Verify Completion of Post Procedure Checklist.

Section Complete QA Witness: _____

Section H.

Completed by: _____

Witnessed by: _____

Date: _____

Time: _____

Quality Manager _____ **Date** _____

Payload Test Director _____ **Date** _____

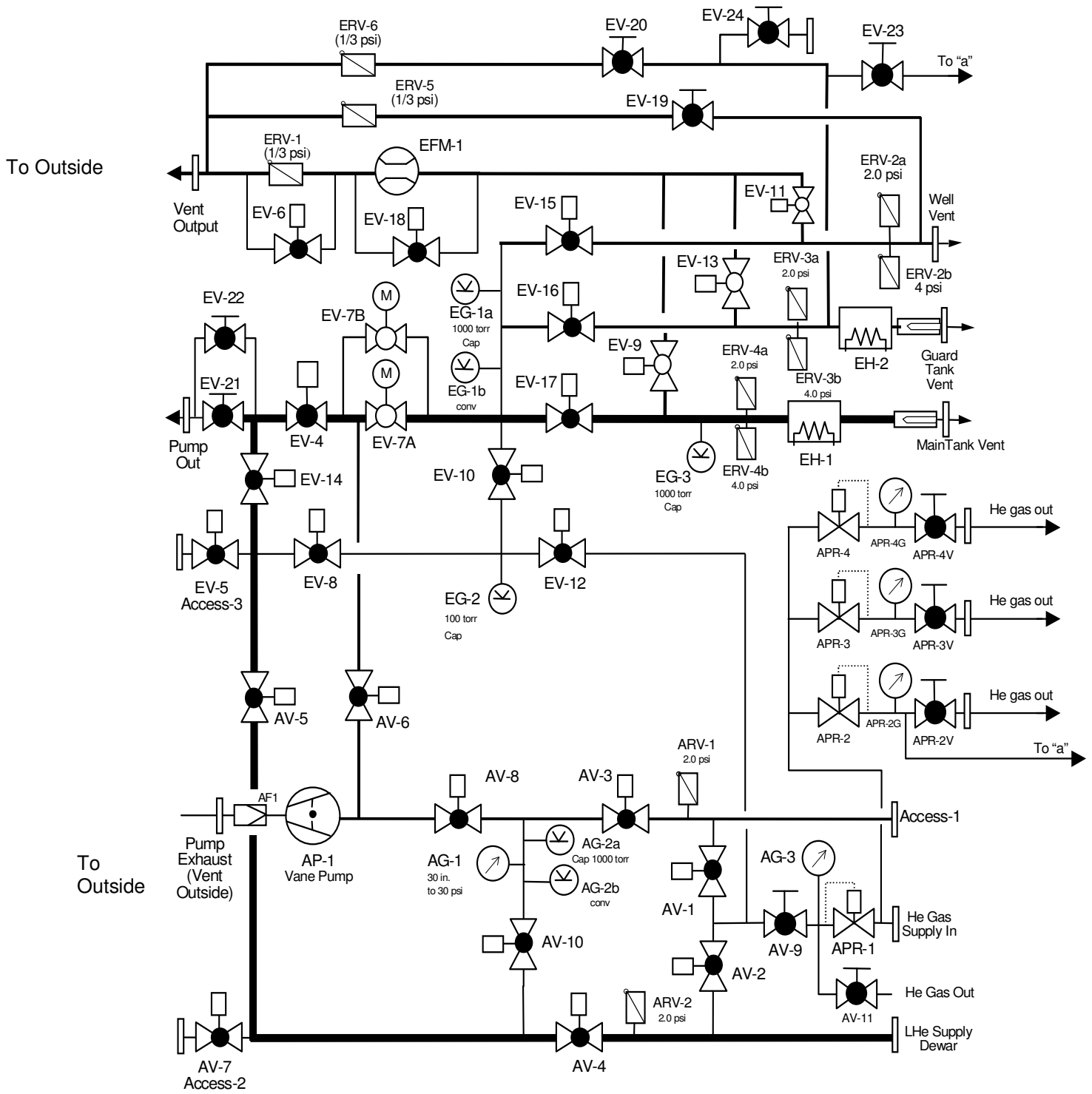
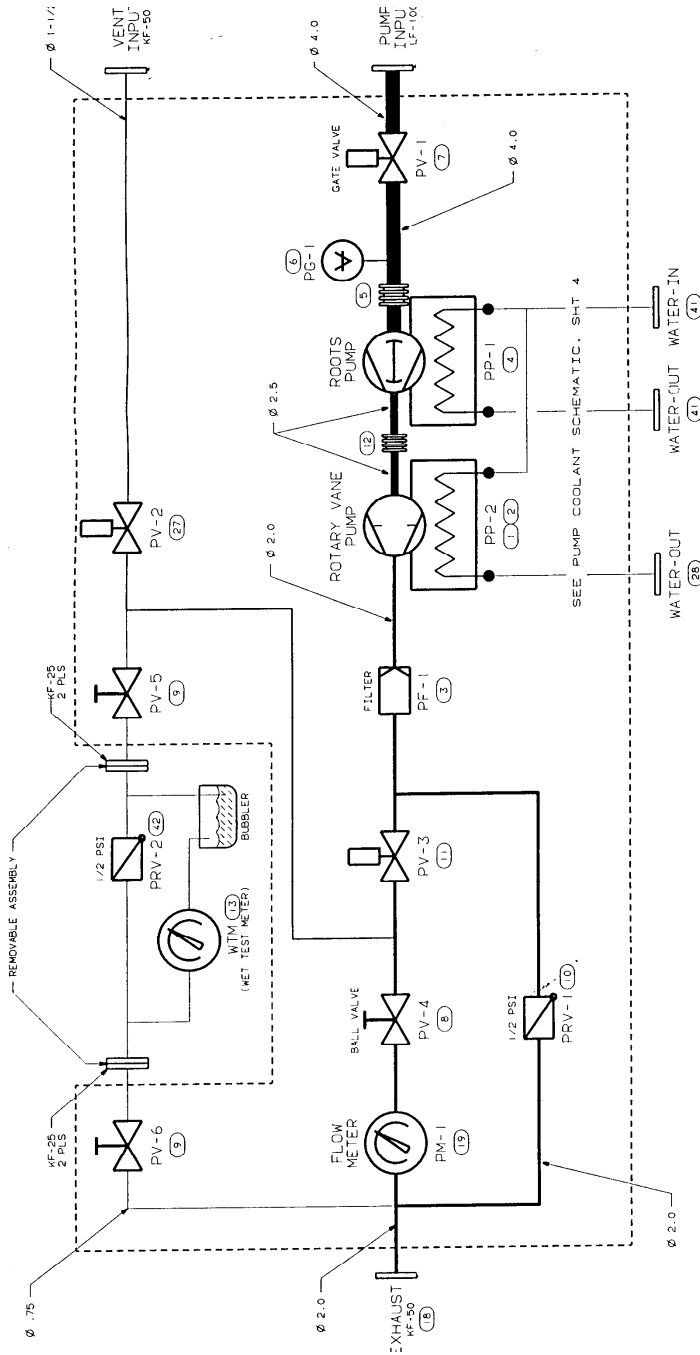

Figure 1. Gas Module

Figure 2-Schematic diagram of the Pump Module



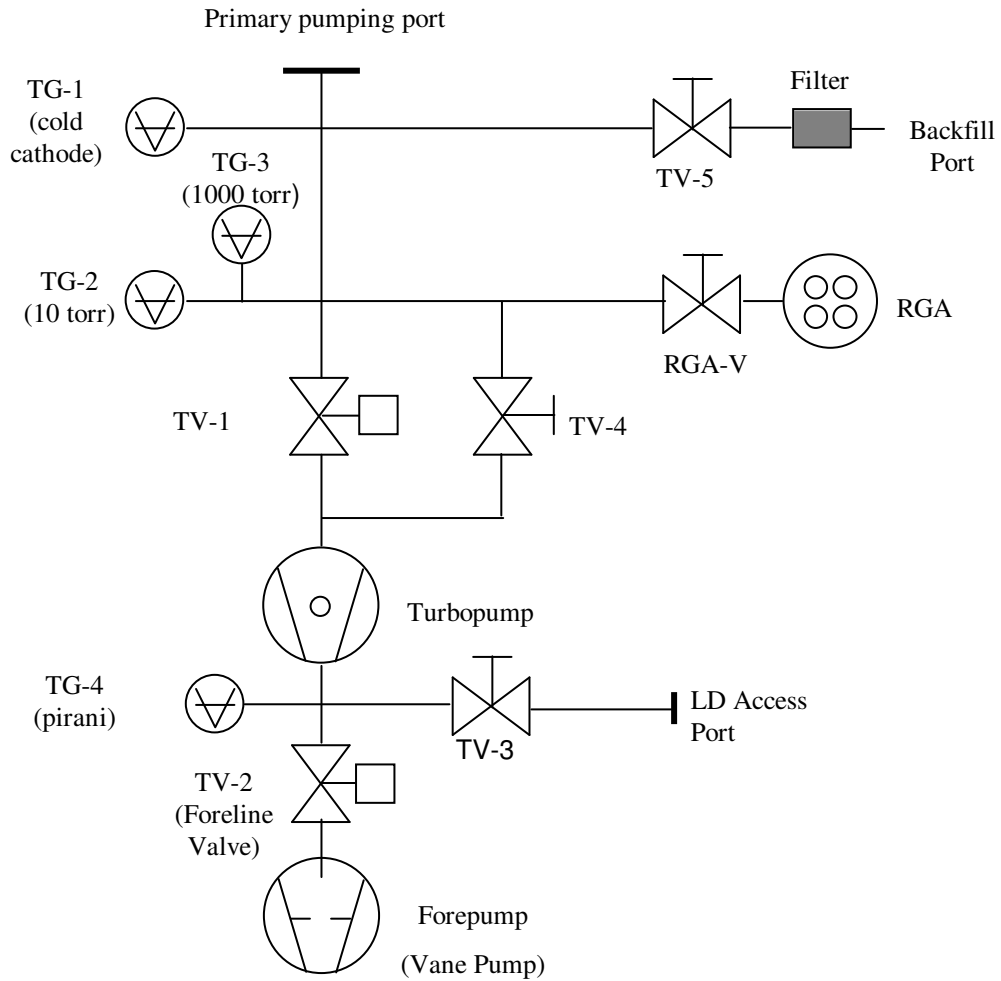

Figure 3. Schematic diagram of Utility Pumping System (UTS)

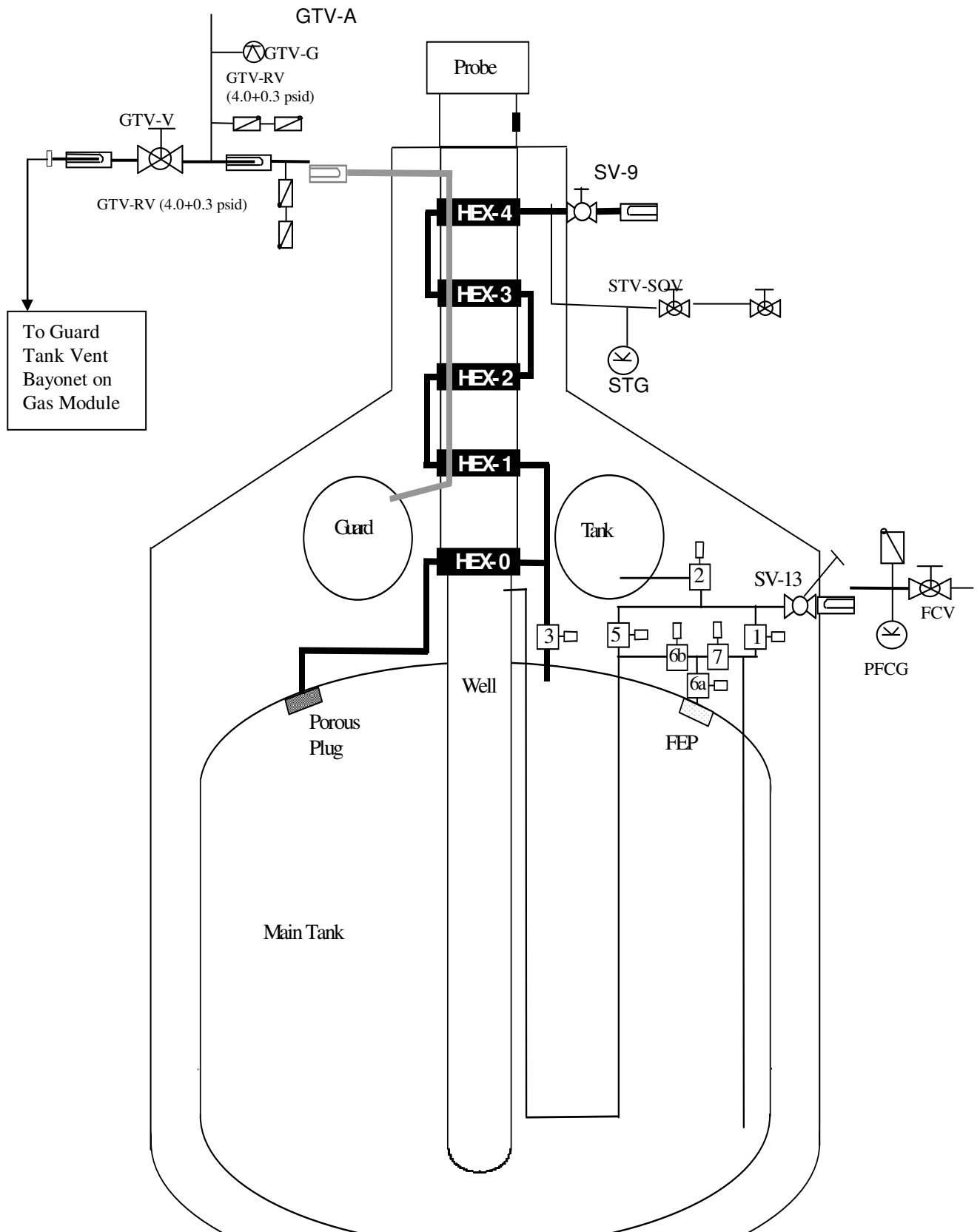

Figure 4. Schematic of Science Mission Dewar plumbing.

Figure 5- Possible Main Tank and Guard Tank Vent Configurations

*note-dashed arrows indicated an option

H.

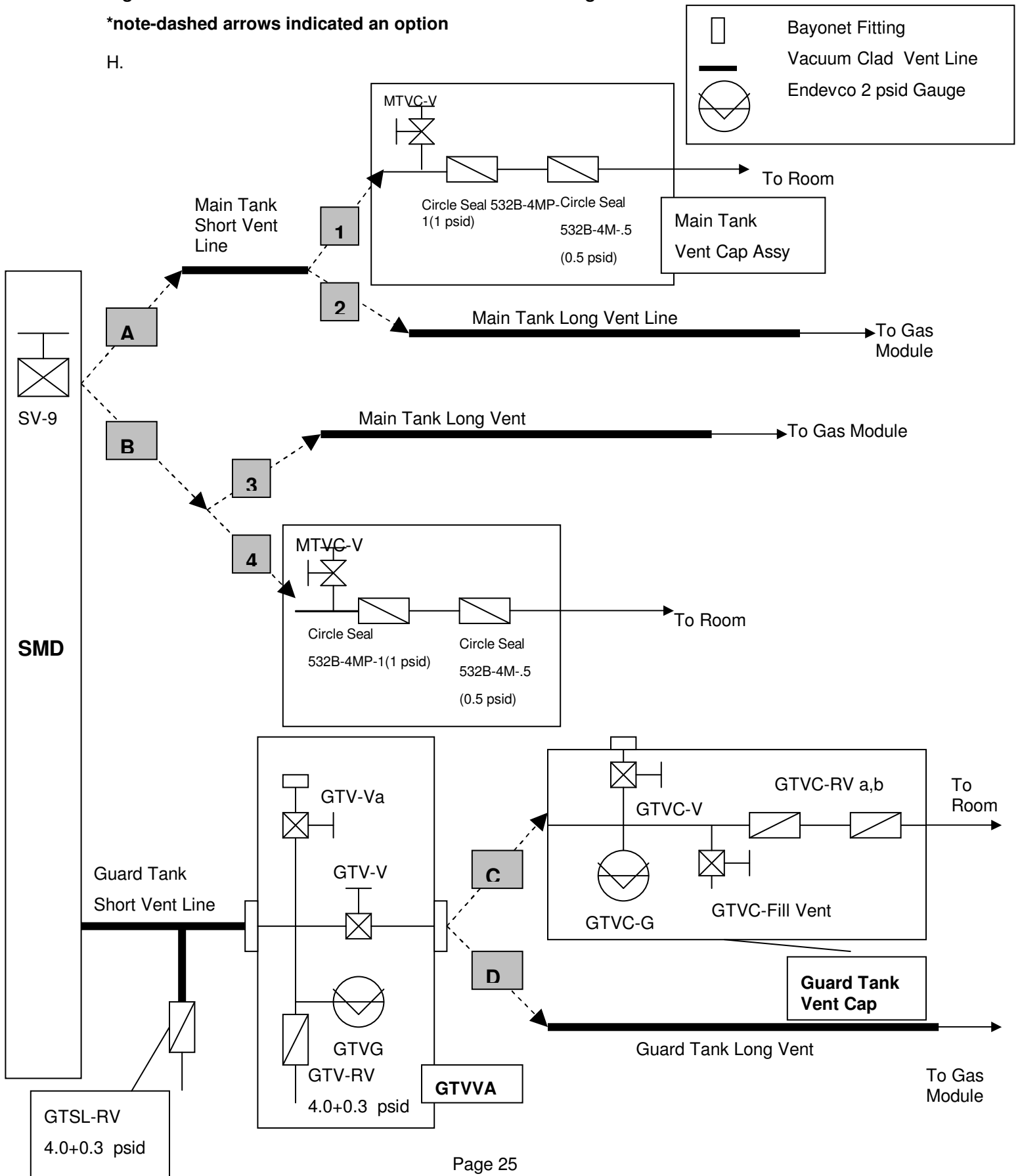
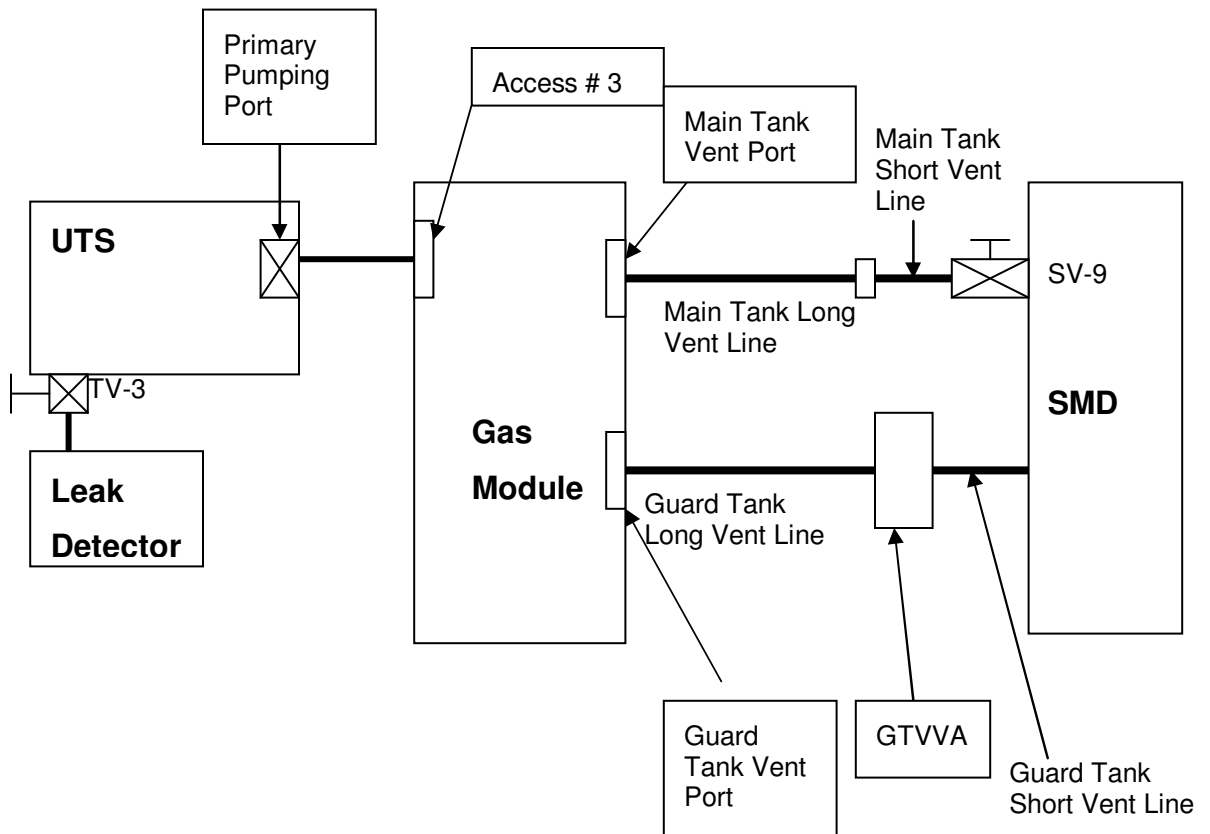

FIGURE 6: BLOCK DIAGRAM OF GSE AND SMD-SEE INDIVIDUAL DIAGRAMS FOR MORE DETAIL



APPENDIX 1 PRE OPERATIONS CHECKLIST

DATE	CHECKLIST ITEM	COMPLETED	REMARKS
	1. Verify the test procedure being used is the latest revision.		
	2. Verify all critical items in the test are identified and discussed with the test team.		
	3. Verify all required materials and tools are available in the test area.		
	4. Verify all hazardous materials involved in the test are identified to the test team.		
	5. Verify all hazardous steps to be performed are identified to the test team.		
	6. Verify each team member knows their individual responsibilities.		
	7. Confirm that each test team member clearly understands that he/she has the authority to stop the test if an item in the procedure is not clear.		
	8. Confirm that each test team member clearly understands that he/she must stop the test if there is any anomaly or suspected anomaly.		
	9. Notify management of all discrepancy reports or d-log items identified during procedure performance. In the event an incident or major discrepancy occurs during procedure performance management will be notified immediately.		
	10. Verify/perform pre-task engineering/safety high bay walk down. Verify noted discrepancies have been corrected.		
	11. Confirm that each test team member understands that there will be a post-test team meeting.		
	Team Lead Signature: _____		

I. **APPENDIX 2** POST Operations CHECKLIST

DATE	CHECKLIST ITEM	COMPLETED	REMARKS
	1. Verify all steps in the procedure were successfully completed.		
	2. Verify all anomalies discovered during testing are properly documented.		
	3. Ensure management has been notified of all major or minor discrepancies.		
	4. Ensure that all steps that were not required to be performed are properly identified.		
	5. If applicable sign-off test completion.		
	Team Lead Signature: _____		

J. **APPENDIX 3– CONTINGENCY RESPONSES**

Condition	Circumstance	Response
Temperature limits (CN 29 or 28) exceeded	When Main Tank is at NBP	Close EV-17 (if open) and open EV-9. Crack open SV-9 to allow MT to vent. Adjust SV-9 as necessary to restore temperature(s) below alarm limits. Open EV-6 and EV-18 if higher flow rate is needed.
Burst disk rupture (MT/GT)	Anytime	Evacuate room
Oxygen Monitor Alarm	Anytime	Evacuate room
Liquid Nitrogen Spill	Anytime	Clear area until liquid has evaporated.