

GRAVITY PROBE-B PROCEDURE FOR SCIENCE MISSION DEWAR

CERTIFY UTS AFTER TRANSPORT

To be performed at Vandenberg Air Force Base building 1610

WARNING: THIS DOCUMENT CONTAINS HAZARDOUS OPERATIONS

P1023

October 28, 2002

Written by:

_____ Date _____
Ned Calder
Cryogenic Test

Approvals:

_____ Date _____
Dorrene Ross
Quality Assurance

_____ Date _____
Harv Moskowitz
LMMS Safety

_____ Date _____
Rob Brumley
Program Technical Manager

_____ Date _____
Mike Taber
Test Director

_____ Date _____
NASA/KSC Safety

REVISION RECORD

REVISION	ECO	PAGES	DATE

Table of Contents

A.	SCOPE	2
B.	SAFETY	2
	B.1. Potential Hazards	2
	B.2. Mitigation of Hazards	2
	B.3. Mishap Notification	3
C.	QUALITY ASSURANCE.....	3
	C.1. QA Notification.....	3
	C.2. Red-line Authority	3
	C.3. Discrepancies	3
D.	TEST PERSONNEL.....	4
	D.1. Personnel Responsibilities.....	4
	D.2. Personnel Qualifications.....	4
	D.3. Required Personnel	4
E.	REQUIREMENTS	4
	E.1. Electrostatic Discharge Requirements.....	4
	E.2. Lifting Operation Requirements	5
	E.3. Hardware/Software Requirements.....	5
	E.4. Configuration Requirements.....	5
	E.5. Optional Non-flight Configurations.....	5
F.	REFERENCE DOCUMENTS	6
	F.1. Drawings.....	6
	F.2. Supporting documentation.....	6
	F.3. Additional Procedures.....	6
G.	OPERATIONS.....	7
	G.1. Pre-Operations Verifications.....	7
	G.2. Establish Initial Condition of UTS.....	7
	G.3. Leak Test UTS.....	11
H.	PROCEDURE COMPLETION.....	12
I.	APPENDIX 1 PRE OPERATIONS CHECKLIST	14
J.	APPENDIX 2 POST OPERATIONS CHECKLIST.....	15
K.	APPENDIX 3– CONTINGENCY/EMERGENCY RESPONSES	16

List of Abbreviations and Acronyms

AG-x	Gauge x of Gas Module auxiliary section	MT	Main Tank
AMI	American Magnetics Inc.	MTVC	Main Tank Vent Cap
ATC	Advanced Technology Center	MTVC-G	Main Tank Vent Cap pressure gauge
APR-x	Pressure regulator x of Gas Module	MTVC-RV	Main Tank Vent Cap relief valve
AV-x	Valve x of Gas Module auxiliary section	MTVC-V	Main Tank Vent Cap valve
CG-x	Gauge x of portable helium pressurization source	NBP	Normal boiling point
CPR-x	Pressure regulator x of portable helium pressurization source	ONR	Office of Naval Research
CV-x	Valve x of portable helium pressurization source	PFCG	Fill Cap assembly pressure Gauge
CN [xx]	Data acquisition channel number	PFM	Pump equipment Flow Meter
DAS	Data Acquisition System	PG-x	Gauge x of Pump equipment
EFM	Exhaust gas Flow Meter	PM	Pump Module
EG-x	Gauge x of Gas Module exhaust section	psi	pounds per square inch
EH-x	Vent line heat exchanger in Gas Module	psig	pounds per square inch gauge
EM	Electrical Module	PTD	Payload Test Director
ERV-x	Relief valve of Gas Module exhaust section	PV-x	Valve x of the Pump equipment
EV-x	Valve number x of Gas Module exhaust section	QA	Quality Assurance
FCV	Fill Cap Valve	RAV-x	Remote Actuated Valve-x
FIST	Full Integrated System Test	RGA	Residual Gas Analyzer
GHe	Gaseous Helium	SMD	Science Mission Dewar
GM	Gas Module	STV	SMD Thruster vent Valve
GP-B	Gravity Probe-B	SU	Stanford University
GSE	Ground Support Equipment	SV-x	SMD Valve number x
GT	Guard Tank	TG-x	Gauge x of Utility Turbo System
GTVC	Guard Tank Vent Cap	TV-x	Valve x of Utility Turbo System
GTVC-G	Guard Tank Vent Cap pressure gauge	UTS	Utility Turbo System
GTVC-RV	Guard Tank Vent Cap relief valve	Vac	Vacuum
GTVC-V	Guard Tank Vent Cap valve	VCP-x	Vent cap pressure gauge
GTV-G	Guard Tank vent pressure gauge	VCRV-x	Vent cap relief valve
GTV-RV	Guard Tank vent relief valve	VCV-x	Vent cap valve
GTV-V	Guard Tank vent valve	VDC	Volts Direct Current
KFxx	Quick connect o-ring vacuum flange (xx mm diameter)	VF-x	Liquid helium Fill line valve
LHe	Liquid Helium	VG-x	Gauge x of Vacuum Module
LHSD	Liquid Helium Supply Dewar	VM	Vacuum Module
LHV-x	Liquid Helium Supply Dewar valves	VV-x	Valve x of Vacuum Module
LLS	Liquid level sensor	VW-x	Valve x of Dewar Adapter

LM Lockheed Martin Co.

LIST OF SPECIFIC HEADING DEFINITIONS

Each type of alert message will precede the procedural step to which it applies

1. NOTE: Used to indicate an operating procedure of such importance that it must be emphasized
2. CAUTION: Used to identify hazards to equipment
3. WARNING: Used to identify hazards to personnel

A. SCOPE

This procedure describes the steps necessary to start up the UTS after transportation, and check all gauges, pneumatic valves, and pumps for proper operation.

The hazardous operation contained in this procedure is the handling of cryogenic nitrogen to service the leak detector.

B. SAFETY**B.1. Potential Hazards**

Personal injury and hardware damage can result during normal positioning, assembly and disassembly of hardware.

Liquid helium used in the SMD represents a hazardous material for the personnel involved in the operations. Cryogenic burns can be caused by contact with the cold liquid or gas, high pressures can result if boiling liquid or cold gas is confined without a vent path, and asphyxiation can result if the vent gas is allowed to accumulate. Liquid Nitrogen is also a potential hazard in this procedure.

The SMD Safety Compliance Assessment, document GPB-100153C and the Missile System Prelaunch Safety Handbook discuss the safety design, operating requirements and the hazard analysis of the SMD.

B.2. Mitigation of Hazards**B.2.1. Lifting hazards**

There are no lifting operations in this procedure

B.2.2. Cryogenic Hazards

In VAFB building 1610, the GP-B cryogenic team provides an oxygen deficiency monitor that alarms when the oxygen level is reduced to 19.5%. Additional temperature and pressure alarms, provided by the DAS, warn of potential over-pressure conditions. Emergency vent lines are installed over the four burst disks to direct any flow to an outside area.

Only authorized and trained personnel are allowed in VAFB facilities without escort. All personnel working on platforms at a height 30 inches or more off the floor are required to have an approved air tank (emergency breathing apparatus) within easy reach. Note that tank need not be kept available when working from ladder. In the unlikely event of a large LHe spill all employees have been instructed to evacuate the room and contact NASA safety.

The following additional requirements apply to all personnel involved directly in cryogenic operations. Gloves that are impervious to liquid helium and liquid nitrogen are to be worn whenever the possibility of

splashing or impingement of high-velocity cryogenics exists or when handling equipment that has been cooled to cryogenic temperatures. Protective clothing, non-absorbent shoes and full-face shields with goggles/glasses are to be worn whenever the possibility of splashing cryogenics exists.

B.2.3. Other Hazards

All tools or other items used with the potential to damage the space vehicle shall be tethered.

B.3. **Mishap Notification**

B.3.1. Injury

In case of any injury or illness requiring emergency medical treatment
DIAL 911

B.3.2. Hardware Mishap

In case of an accident, incident, or mishap, notification is to proceed per the procedures outlined in Lockheed Martin Engineering Memorandum EM SYS229 and Stanford University GP-B P0879. Additionally, VAFB NASA Safety and 30th Space Wing Safety will be notified as required.

B.3.3. Contingency Response

Responses to contingencies/emergency (e.g., power failure) are listed in Appendix 3.

C. **QUALITY ASSURANCE**

C.1. **QA Notification**

The NASA program and NASA Safety representative and SU QA shall be notified 24 hours prior to the start of this procedure. Upon completion of this procedure, the QE Manager will certify his/her concurrence that the effort was performed and accomplished in accordance with the prescribed instructions by signing and dating in the designated place(s) in this document.

C.2. **Red-line Authority**

Authority to red-line (make minor changes during execution) this procedure is given solely to the TD or his designate and shall be approved by the QA Representative. Additionally, approval by the Payload Technical Manager shall be required, if in the judgement of the TD or QA Representative, experiment functionality may be affected. Within hazardous portions of this procedure, all steps shall be worked in sequence. Out of sequence work or redlines shall be approved by NASA Safety prior to their performance

C.3. **Discrepancies**

A Quality Assurance Representative designated by D. Ross shall review any discrepancy noted during this procedure, and approve its disposition.
Discrepancies will be recorded in a D-log or a DR per Quality Plan P0108. Any

time a procedure calls for verification of a specific configuration and that configuration is not the current configuration, it represents a discrepancy of one of three types. These types are to be dealt with as described below.

1. If the discrepancy has minimal effect on procedure functionality (such as the state of a valve that is irrelevant to performance of the procedure) it shall be documented in the procedure, together with the resolution. Redlines to procedures are included in this category.
2. If the discrepancy is minor and affects procedure functionality but not flight hardware fit or function, it shall be recorded in the D-log. Resolution shall be in consultation with the PTD and approved by the QA representative.
3. All critical and major discrepancies, those that effect flight hardware fit or functions, shall be documented in a D-log and also in a Discrepancy Report, per P0108.

D. TEST PERSONNEL

D.1. Personnel Responsibilities

The performance of this procedure requires a minimum complement of personnel as determined by the Test Director. The person performing the operations (Test Director or Test Engineer) is to sign the "Completed by" sign-off. Any other qualified person or QA person who can attest to the successful performance of this procedure may sign the "Witnessed by" sign-off. The Test Director will perform Pre-Test and Post-Test Briefings in accordance with P0875 "GP-B Maintenance and Testing at all Facilities." Checklists will be used as directed by P0875

D.2. Personnel Qualifications

The Test Director must have a detailed understanding of all procedures and facility operations and experience in all of the SMD operations. Test Engineers must have SMD Cryogenic operations experience and an understanding of the operations and procedures used for the cryogenic servicing/maintenance of the Dewar.

D.3. Required Personnel

The following personnel are essential to the accomplishment of this procedure:

FUNCTIONAL TITLE	NUMBER	AFFILIATION
Test Director/Test Engineer	1	Stanford
GP-B Quality Assurance	1	Stanford
NASA Safety Rep	1	SFAO or ANALEX

E. REQUIREMENTS

E.1. Electrostatic Discharge Requirements

When working on the space vehicle, proper ESD protection is required. ESD wrist-straps will be checked on a calibrated checker prior to use.

E.2. Lifting Operation Requirements

There are no lifting operations in this procedure

E.3. Hardware/Software Requirements

E.3.1. Ground Support Equipment

None required

E.3.2. Test Equipment

<i>Description</i>
Varian Leak Detector S/N # _____ Cal Due Date: _____

E.3.3. Additional Hardware

1. 4 liter cryogenic thermos (used for nitrogen trap fills)

E.3.4. Tools

None required

E.3.5. Personnel Protective Equipment

1. Cryogenic safety gloves and apron
2. Face Shield
3. Goggles/glasses
4. Non-absorbent shoes

E.3.6. Expendables

Description	Quantity	Mfr./Part No.
Liquid nitrogen	AR	N/A
99.999% pure helium gas	AR	N/A

E.4. Configuration Requirements

N/A

E.5. Optional Non-flight Configurations

N/A

F. REFERENCE DOCUMENTS**F.1. Drawings**

<i>Drawing No.</i>	<i>Title</i>
LMMS-5833394	Instrumentation Installation

F.2. Supporting documentation

<i>Document No.</i>	<i>Title</i>
LMMC-5835031	GP-B Magnetic Control Plan
GPB-100153C	SMD Safety Compliance Assessment
LM/P479945	Missile System Prelaunch Safety Package
SU/GP-B P0141	FIST Emergency Procedures
LMSC-P088357	Science Mission Dewar Critical Design Review
SU/GP-B P0108	Quality Plan
LMMS GPB-100333	Science Mission Dewar Failure Effects and Causes Analysis
SU/GP-B P059	GP-B Contamination Control Plan
EM SYS229	Accident/Mishap/Incident Notification Process
EWR 127-1	Eastern and Western Range Safety Requirements
KHB 1710.2 rev E	Kennedy Space Center Safety Handbook

F.3. Additional Procedures

<i>Document No.</i>	<i>Title</i>
SU/GP-B P0879	Accident/Incident/Mishap Notification Process
SU/GP-B P1015	Connect Vacuum Module to SMD
SU/GP-B P0875	GP-B Maintenance and Testing at all Facilities
SU/GP-B P1024	Prepare Payload GSE for Transport

Operation Number: _____

Date Initiated: _____

Time Initiated: _____

G. OPERATIONS**G.1. Pre-Operations Verifications**

- o Verify SU QA notified.

Record: Individual notified _____,

Date/time ____/____.

- o Verify NASA program representative notified.

Record: Individual notified _____,

- o Verify NASA safety representative notified and concurrence has been given to proceed.

Record: Individual notified _____

Date/Time: _____,

- o Record calibration due dates in sections. E.3.2
- o Persons actually performing this procedure should list their names in Sec D.3.
- o Verify completion of the pre-operations checklist (Appendix 1).
- o Verify proper operation of GP-B Cryogenic Team oxygen monitor
- o Verify availability and functioning of emergency shower

Section Complete QA Witness: _____

G.2. Establish Initial Condition of UTSG.2.1. Visually inspect UTS. Record damage: _____

G.2.2. Verify all access ports are capped.

1. Primary pump-out port (at TV-1)
2. Leak Detector port (TV-3)

G.2.3. Ensure over-ride switch in protect position.

G.2.4. Ensure valves TV-3, TV-4, TV-5, TV-6 and RGA-V are closed.

G.2.5. Start compressor to pressurize air for pneumatic valve operation.

G.2.6. Turn on converter

Note:

The converter switch provides power to turbopump controller and pirani and cold-cathode vacuum-gauge display.

G.2.7. Record status of pneumatic valves per lighted switches.

<i>Valve</i>	<i>Switch Light on (Open)</i>	<i>Switch Light off (Closed)</i>	<i>Expected Status</i>
TV-1 (Gate Valve)			Closed
TV-2 (Foreline Valve)			Closed

G.2.8. Turn on/verify on pressure gauges TG-2, and TG-3.

G.2.9. Push the “Sensor” button on the vacuum gauge display to read the foreline pressure (TG-4).

Note:
This is the pirani gauge. The “Pir” annunciator will appear in upper left corner of the display.

G.2.10. Verify UTS shut down according to procedure P0792 or P1023, *Prepare Payload GSE for Transport*.

Record Operation Number _____ and date _____.

Note:
If UTS not shut down according to P0792 or P1023 the expected values in the following step may not be obtained.

G.2.11. Record pressures and compare to expected values. If pressures are significantly higher than expected, a leak may be indicated. In any case, continue with the remainder of the procedure.

<i>Actual Reading</i>	<i>Expected Reading (approximate)</i>
TG-2 _____ torr	< 10 torr
TG-3 _____ torr	< 10 torr
TG-4 _____ torr	< 10 torr

G.2.12. Verify normal operation of TV-2 and rotary vane pump (Fore pump) as follows:

1. Place valve interlock switch in “over-ride” position.
2. Record pressures
 - a. TG-3 _____ torr.
 - b. TG-4 _____ torr.
3. Turn on vane pump while checking for proper rotation.
4. Push the red “reset” button to activate the interlock over-ride circuit. (the yellow-orange indicator light will come on).
5. Turn “foreline” switch on, to open TV-2. Verify that the switch illuminates.
6. When pressure at TG-4 < 25 mtorr, record pressures
 - a. TG-3 _____ torr.
 - b. TG-4 _____ torr.
7. Verify decrease in pressure TG-4 to verify pump operating and TV-2 opened.
8. Verify pressure at TG-3 unchanged to verify TV-1 is closed.
9. When satisfied vane pump is operating normally, TV-2 opened, and TV-1 is closed (TG-4 < 25 mtorr), proceed to next step.

G.2.13. Verify normal operation of TV-1.

1. Record pressures
 - a. TG-3 _____ torr.
 - b. TG-4 _____ torr.
2. Close TV-2.
3. Open TV-1 (Verify that switch illuminates).
4. When pressures TG-3 and TG-4 stabilize, record

- a. TG-3 _____ torr.
 - b. TG-4 _____ torr.
 5. Verify increase in pressure at TG-4 and decrease in pressure TG-3 to verify TV-1 opened).
 6. Wait 1 minute then record pressures:
 - a. TG-3 _____ torr.
 - b. TG-4 _____ torr.
 7. Verify pressures TG-3 and TG-4 remain unchanged (or increase slightly) to verify TV-2 closed.
 8. When satisfied TV-1 opened normally and TV-2 closed normally, close TV-1.
 9. Open TV-2.
 10. Wait 1 minute and record pressures:
 - a. TG-3 _____ torr.
 - b. TG-4 _____ torr.
 11. Verify that TV-4 decreased and TV-3 remained unchanged (or increased slightly) to verify TV-1 closed.
 12. When satisfied TV-1 and TV-2 operate normally proceed to next step.
- G.2.14. Verify normal operation of turbo pump.
1. Record date/time: _____ / _____
 2. Verify closed/close TV-1.
 3. Verify open/open TV-2.
 4. Slowly open TV-4.
 5. When foreline pressure (TG-4) < 1 torr, push "Start" button on turbo controller.
 6. When the "Normalbetrieb" light illuminates on turbo controller, indicating turbopump is up to speed, open gate valve TV-1 and close TV-4.
 7. Switch the valve interlock switch to the "protected" position.
 8. Push the "Sensor" button on the vacuum gauge readout so that the "Hi-Vac" annunciator shows, and push the "Emis" button to turn on the cold cathode gauge (TG-1).
 9. Record the "Hi-Vac" pressure (TG-1) _____ torr.
 10. Continue evacuation up to capped-off pump-out port until the pressure at TG-1 is < 1.0×10^{-6} torr then record:

- a. Time of day:_____
- b. TG-1 pressure:_____ torr.

11. When satisfied that turbo is operating normally, the procedure to certify operation of the UTS is complete.

Section Complete QA Witness:_____

WARNING

The following operations involve steps that pose a cryogenic safety hazard. When filling the nitrogen trap in the leak detector, wear cryogenic safety apron, gloves, face shield with goggles/glasses, and non-absorbent shoes. Failure to comply may result in personal injury.

G.3. Leak Test UTS

- G.3.1. Ensure a six foot clear area established around leak detector
- G.3.2. Request NASA Safety make PA an announcement that hazardous task is about to begin.
- G.3.3. Request area warning light be turned to Amber.
- G.3.4. Ensure all nonessential personnel are clear of controlled area.
- G.3.5. Turn on and verify calibration of leak detector. Record
 - 1. Calibrated leak value _____ sccs; cal exp.
Date:_____
 - 2. Measured leak value _____ sccs

NOTE

The hazardous operations are now complete.

- G.3.6. Request PA announcement that hazardous operations are complete.
- G.3.7. Request area operations light be turned to Green
- G.3.8. Disband controlled area
- G.3.9. Connect leak detector to the UTS at access port (LD).
- G.3.10. Leak test the system up to closed valve TV-3
- G.3.11. Turn the leak detector's vent disable switch to the disabled position.
- G.3.12. Slowly open leak detector access valve TV-3. Monitor the system pressure, as read on gauge TG-1, as this valve is opened to ensure it does not rise above 1×10^{-5} torr.
- G.3.13. Close valve TV-2.
- G.3.14. Leak test all pumping lines and connections.
- G.3.15. Record Leak detector readings:
 - 1. Initial background:_____sccs He
 - 2. Final reading:_____sccs He

- G.3.16. Verify no leaks $> 1.0 \times 10^{-7}$ sccs are present.
- G.3.17. Open valve TV-2.
- G.3.18. Close valve TV-3.
- G.3.19. Turn the leak detector's vent disable switch to the off position.
- G.3.20. Vent the leak detector to air.
- G.3.21. Disconnect the leak detector from the leak check access port.
- G.3.22. Verify Completion of the Post Operations Checklist

Section Complete QA
Witness: _____

H. PROCEDURE COMPLETION

Completed by: _____

Witnessed by: _____

Date: _____

Time: _____

Quality Manager _____ **Date** _____

Payload Test Director _____ **Date** _____

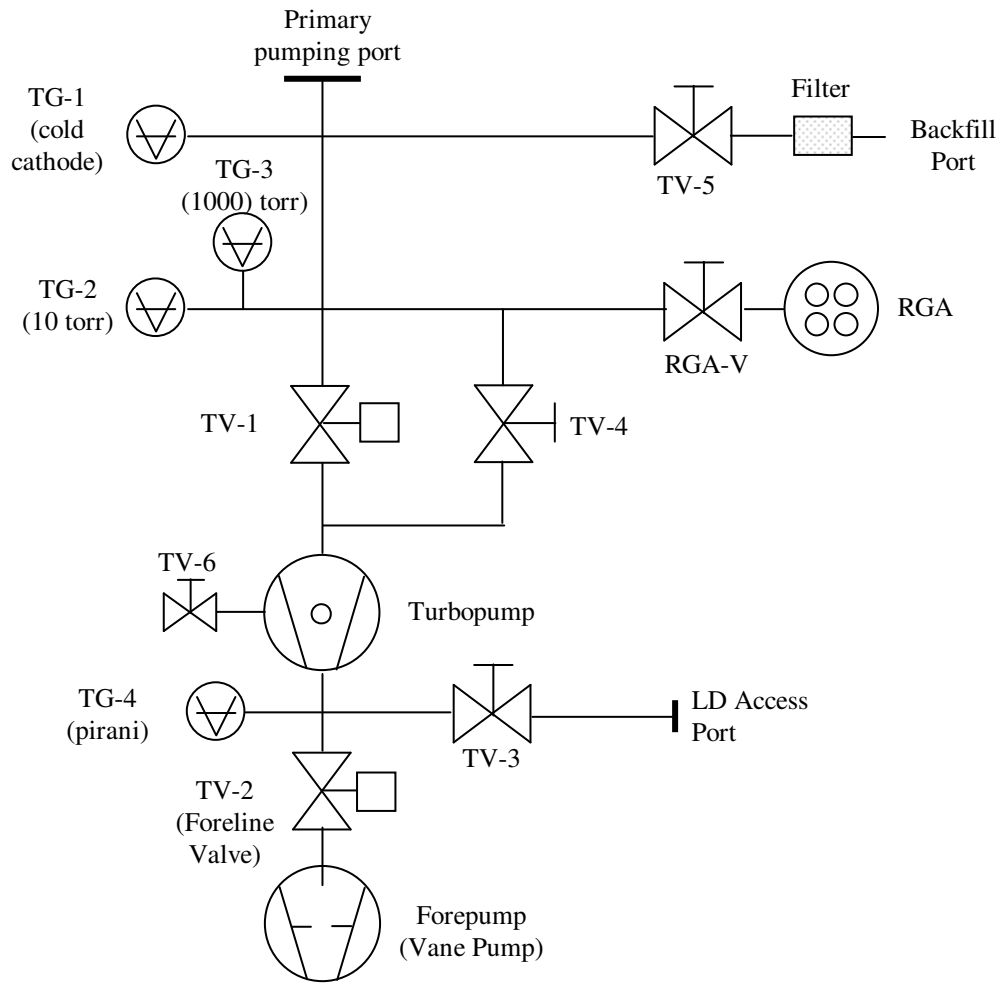

Figure 1. Schematic diagram of Utility Pumping System (UTS)

I. APPENDIX 1 PRE OPERATIONS CHECKLIST

DATE	CHECKLIST ITEM	COMPLETED	REMARKS
	1. Verify the test procedure being used is the latest revision.		
	2. Verify all critical items in the test are identified and discussed with the test team.		
	3. Verify all required materials and tools are available in the test area.		
	4. Verify all hazardous materials involved in the test are identified to the test team.		
	5. Verify all hazardous steps to be performed are identified to the test team.		
	6. Verify each team member is certified for the task being performed and knows their responsibilities.		
	7. Confirm that each test team member clearly understands that he/she has the authority to stop the test if an item in the procedure is not clear.		
	8. Confirm that each test team member clearly understands that he/she must stop the test if there is any anomaly or suspected anomaly.		
	9. Notify management of all discrepancy reports or d-log items identified during procedure performance. In the event an incident or major discrepancy occurs during procedure performance management will be notified immediately.		
	10. Perform engineering and Safety high bay walk down. Verify all discrepancies have been corrected.		
	11. Confirm that each test team member understands that there will be a post-test team meeting.		
	Team Lead Signature: _____		

J. APPENDIX 2 POST OPERATIONS CHECKLIST

DATE	CHECKLIST ITEM	COMPLETED	REMARKS
	1. Verify all steps in the procedure were successfully completed.		
	2. Verify all anomalies discovered during testing are properly documented.		
	3. Ensure management has been notified of all major or minor discrepancies.		
	4. Ensure that all steps that were not required to be performed are properly identified.		
	5. If applicable sign-off test completion.		
	6. Verify all RAV valve operations have been entered in log book		
	7. Verify the as-run copy of procedure has been filed in the appropriate binder		
	Team Lead Signature: _____		

K. **APPENDIX 3– CONTINGENCY/EMERGENCY RESPONSES**

Condition	Circumstance	Response
Power Failure	Anytime	Wait for power restoration, and resume procedure
Liquid nitrogen spill	Anytime	Clear area until all spilled liquid has evaporated
Temperature limits (CN 29 or 28) exceeded	Any time	Close EV-17 (if open) and open EV-9. Crack open SV-9 to allow MT to vent. Adjust SV-9 as necessary to restore temperature(s) below alarm limits. Open EV-6 and EV-18 if higher flow rate is needed.
Burst disk rupture (MT/GT)	Any time	Evacuate room
Pressure in Main Tank exceeds limit	Anytime	Open Main Tank Vent Valve
Oxygen monitor Alarm	Anytime	Evacuate